

Quick Guide

Ver. 1.5
Release date: VIII 2025
Soft:
Main module: v2.0.2
MCU: v0.4.1

Works with
ENGO SMART App
GET IT ON
Google Play
Available on the
App Store
Hey Google works with alexa

Powered By
tuya

Producer:
Engo Controls sp. z o.o. sp. k.
Rolna 4
43-262 Kobielice
Poland

www.engocontrols.com

Product Compliance

This product complies with the following EU Directives: 2014/53/EU i 2011/65/EU.

Safety information:

Use in accordance with national and EU regulations. Use the device only as intended, keeping it in a dry condition. The product is for indoor use only. Please read the entire manual, before installation or use.

Installation

Installation must be performed by a qualified person with appropriate electrical qualifications, in accordance with the standards and regulations in force in a given country and in the EU. The manufacturer is not responsible for non-compliance with the instructions.

WARNING:

For the entire installation, there may be additional protection requirements, which the installer is responsible for.

Introduction

Controller for fan coil units or trench heaters with fan, ideal for both 2-pipe and 4-pipe systems. It offers flexible control of 3-speed 230V fans, automatically adjusting the fan speed as required. Frost protection mode and overheat protection functions guarantee safety, while the built-in ECO mode saves energy, resulting in lower energy bills. With support for mixed systems (fan coil and underfloor heating), the EFAN230 is a complete solution for anyone who wants to ensure thermal comfort in their home or office.

Technical data

Power supply	230V AC 50 Hz
Setpoint temp. range	5,0°C to 45,0°C
Display temp. accuracy	0,1 or 0,5°C
Control algorithm	Delta FAN, Hysteresis (±0,1...±2°C), TPI (for underfloor heating)
Communication	Wi-Fi 2,4GHz
Input A+/B-	Modbus RS-485
Inputs	S1/COM, S2/COM - temp. sensor or volt-free contact
Valve control outputs	V1, V2 - 230V AC, 5(2)A
Fan control outputs	F1, F2, F3 - 230V AC, 5(2)A
Dimmension	90 x 90 x 44 mm (13 mm after mounting in a box with a diameter of 60)

Products features

- Wi-Fi 2.4 GHz communication standard
- Modbus RS-485 communication
- Control of 2 or 4 pipe fan coil units
- Support for fans 3-speed 230V
- Combined system control
- Compatibility with the ENGO Smart application (in Tuya Cloud technology)
- Measurement of humidity and temperature
- ECO mode
- Easy installation and configuration

LCD icons Description + Button Description

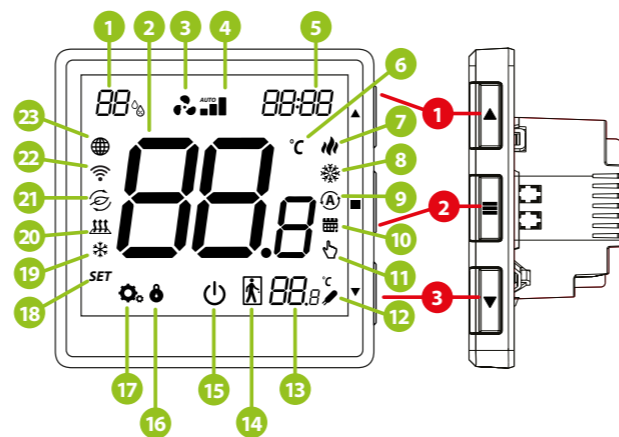

- 1. Humidity display
 - 2. Room temp
 - 3. Fan icon (it is animating when fan is running)
 - 4. Fan Speed (LO, ME, HI, AUTO, OFF)
 - 5. Clock
 - 6. Celcius unit
 - 7. Heating mode icon
 - 8. Cooling icon
 - 9. AUTO Heat/Cool active
 - 10. Schedule icon
 - 11. Manual or temporary override mode
 - 12. Pipe sensor (2-PIPE) or external temp sensor
 - 13. Temp value of the additional sensor
 - 14. Occupancy sensor - connected to S2-COM
 - 15. Power OFF icon
 - 16. Key lock
 - 17. Parameters icon
 - 18. Setting icon (set value icon)
 - 19. Frost mode icon
 - 20. Underfloor heating icon
 - 21. ECO mode icon
 - 22. WiFi connection
 - 23. Cloud connection
1. "UP" button
2. "OK" button
3. "DOWN" button

▲	Change the parameter value up
▼	Change the parameter value down
≡	Manual/Schedule mode - short button press (online mode)
≡	Enter the installer parameters- hold 3 seconds
≡	Turn OFF/ON thermostat - hold 5 seconds
▲ + ▼	Enter the pairing mode - hold until the PA message appears
▲ + ▼	Factory reset - hold until the FA message appears
▲ + ≡	Lock/Unlock thermostat keys - hold 3 seconds
▼ + ≡	Heating/Cooling mode change - hold 3seconds

Wall mounting

To properly install the controller, follow the steps below:

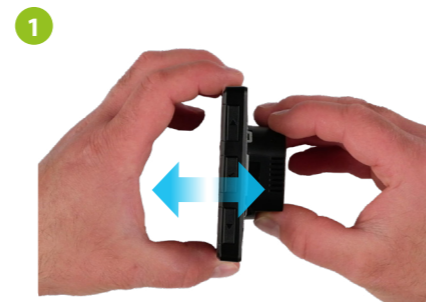

Grab the top part and the bottom part to disconnect

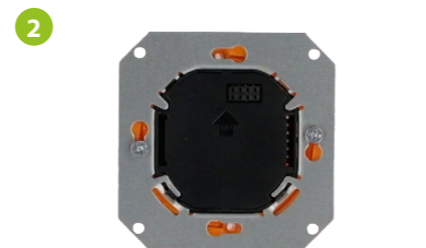

Connect the wires, and then screw back parts to the mounting box.



Slide the front of the controller over the back part. Turn on the power supply. The controller is ready for operation.

Connection description and EFAN thermostat configuration instructions

2-pipe fan coil (heating and/or cooling)

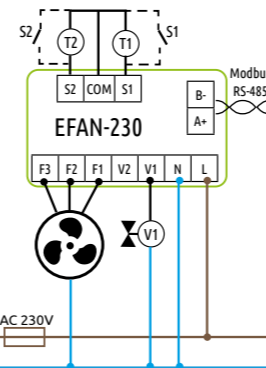

- Use the ▲ or ▼ button select 2-pipe system. Then confirm with ≡ button.
- Press ▲ or ▼ button to select operating mode:
 - a) Fan coil heating in a 2-pipe system
 - b) Fan coil cooling in a 2-pipe system
 - c) Fan coil heating and cooling in a 2-pipe system
 - d) UFH and 2-pipe fan coil in heating/cooling mode
 Confirm your selection with ≡ button.

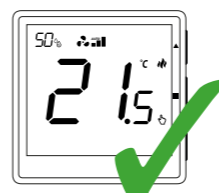

The controller is configured for a 2-pipe system.

4-pipe fan coil (heating and cooling or underfloor heating and fan coil for cooling)

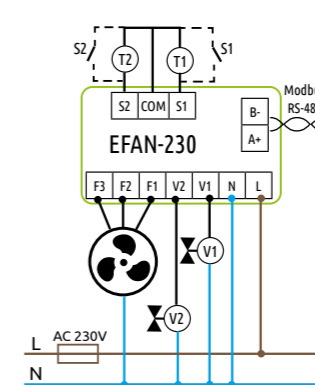

- Use the ▲ or ▼ button select 4-pipe system. Then confirm with ≡ button.
- Press ▲ or ▼ button to select operating mode:
 - a) Fan coil heating and cooling in a 4-pipe system
 - b) Underfloor heating and fan coil cooling
 Confirm your selection with ≡ button.

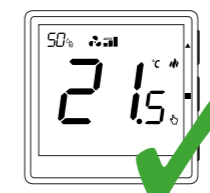

The controller is configured for a 4-pipe system.

Underfloor heating

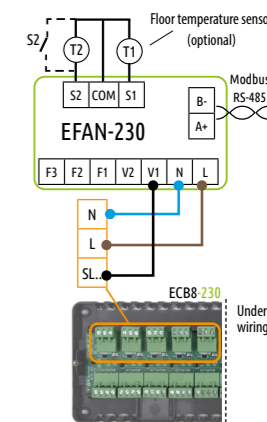

- Use the ▲ or ▼ button select 2-pipe system. Then confirm with ≡ button.
- Press ▲ or ▼ button to select operating mode:
 - a) Underfloor heating
 Confirm your selection with ≡ button.

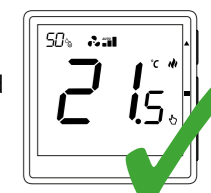

The controller is configured for underfloor heating.

Controller connection terminals:

- L, N Power supply 230V AC
- F1 Output 230V AC - I low fan speed
- F2 Output 230V AC - II medium fan speed
- F3 Output 230V AC - III high fan speed
- A+ / B- Modbus RS-485 terminals
- V1 2-pipe: control output 230V AC - heating and/or cooling valve
- V2 2-pipe: not active
- S1 Volt-free input of a switch or temperature sensor EFS300 on the pipe (change of heating/cooling mode)
- S2 Volt-free switch input (for occupancy sensor - hotel card) or external temperature sensor (EFS300)
- COM GND for the sensor/contact

Legend for diagrams:

- Fuse
- External contact
- Valve actuator
- Temperature sensor
- 3-speed fan 230V AC

Installation of the Wi-Fi thermostat in the app

Make sure your router is within range of your smartphone. Make sure you are connected to the Internet. This will reduce the pairing time of the device.

STEP 1 - DOWNLOAD ENGO SMART APP

Download the ENGO Smart app from Google Play or Apple App Store and install it on your smartphone.



STEP 2 - REGISTER THE NEW ACCOUNT

To register a new account, please follow the steps below:

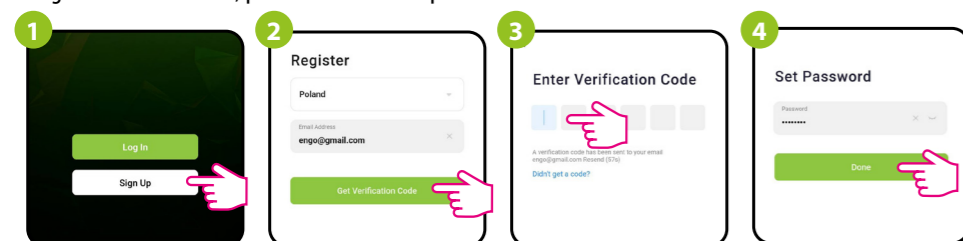

Click „Sign Up“ to create new account.

Enter your e-mail address to which the verification code will be sent.

Enter the verification code received in the email. Remember that you only have 60 seconds to enter the code!

Then set the login password.

STEP 3 - CONNECT THE THERMOSTAT TO WI-FI

After installing the app and creating an account:

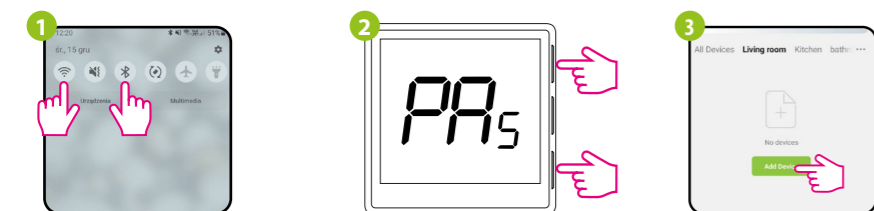

On your mobile device, make sure the ENGO Smart has access to permissions (Location, Bluetooth, Nearby devices). Then turn on Bluetooth and Location. Connect to 2.4GHz Wi-Fi network to which you want to assign the device.

Make sure the thermostat is powered on and configured. Then press and hold the buttons on the thermostat for approx. 3 seconds until the display shows „PA“. Then release the keys. The pairing mode will be started up.

In the app, select: „Add Device“.

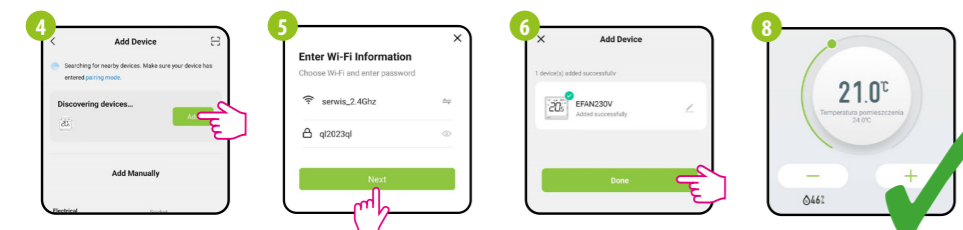

After finding the thermostat, go „Add“.

Select the Wi-Fi network in which the thermostat will operate and enter the password of this network.

Name the device and click „Done“.

The thermostat has been installed and displays the main interface.

Installer parameters

To enter installer parameters press and hold button for 3 seconds.



Use or button to move between parameters. Enter the parameter by . Edit the parameter using or . Confirm the new parameter value with the button.

Pxx	Function	Value	Description	Default value
ConF	Read-only parameter	-	Preview of the current controller configuration	-
P01	S1 - COM input configuration	0	None connected	0
		1	Input used to change heating/cooling via contact external connected to S1-COM: - S1-COM open--> HEAT mode - S1-COM short-circuited--> COOLING mode	
		2	In a 2-pipe system, the S1-COM input is used for automatic switching between heating and cooling modes based on the pipe temperature. The mode changes according to the thresholds set in parameters P17 (heating) and P18 (cooling). In a 4-pipe system, when parameter P01 is set to 2, the controller automatically switches between heating and cooling modes based on the room air temperature, taking into account the dead zone defined by parameter P16.	
		3	Fan operation permit dependent on temperature measurement on the pipe. E.g. if the temperature on the pipe is too low and the regulator is in heating mode - the pipe sensor will not allow you to start fan. The change of heating/cooling is done manually - using the buttons. Values for fan control based on pipe temperatures are set in parameters P17 and P18.	
P02	S2 - COM input configuration	0	None connected	0
		1	When the contacts are open switch on Eco Mode	
		2	External temperature sensor	
P03	Display temp accuracy	0,1°C 0,5°C	Indication of room temperature with an accuracy of 0,1°C Indication of room temperature with an accuracy of 0,5°C	0,1°C
P04	Offset temperature	-3.0°C to +3.0°C	If the thermostat indicates wrong temperature, you can correct it by max ± 3.0°C	0°C
P05	Maximum temperature setpoint	5°C - 45°C	Maximum heating / cooling temperature that can be set	35°C
P06	Minimum temperature setpoint	5°C - 45°C	Minimum heating / cooling temperature that can be set	5°C
P07	ECO mode	NO	Function disabled	NO
		YES	Function enabled	
P08	ECO temp value in HEAT mode	5°C - 45°C	ECO temp value in HEAT mode	15°C
P09	ECO temp value in COOL mode	5°C - 45°C	ECO temp value in COOL mode	30°C
P10	FAN Control - Delta FAN Algorithm for Heating	0,5°C - 5°C	The parameter determines the width of the temperature range in which fan operates in heating mode. If the room temperature drops: 1. When the Delta FAN value is small, the faster the fan response temperature change - faster speed increase 2. When the Delta FAN value is high, the slower the fan increases speed	2°C
P11	Fan ON temperature in heating mode	0°C - 5°C	The fan will start operating if the room temperature drops below the set temperature by the value of parameter	0,5°C
P12	Hysteresis for HEATING valve	0,1°C - 2°C	Hysteresis value for the heating valve	0,5°C
P13	Heat Cool switching - Dead zone for 4-pipe system	0,5°C - 5°C	The parameter determines the width of the temperature range in which fan operates in cooling mode. If the room temperature rises: 1. When the Delta FAN value is small, the faster the fan response temperature change - faster speed increase 2. When the Delta FAN value is high, the slower the fan increases speed	2°C
P14	Fan ON temperature in cooling mode	0°C - 5°C	The fan will start operating if the room temperature rises above the set temperature by the value of parameter	0,5°C
P15	Hysteresis for cooling valve	0,1°C - 2°C	Hysteresis value for the COOLING valve	0,5°C

Installer parameters

P16	Heat Cool switching - Dead zone for 4-pipe system	0,5°C - 5°C	The value of the difference between the set temperature and the temperature of the room so that the controller automatically changes the Heating/cooling operations	2°C
P17	In a 2-pipe system, below this value the system switches to cooling mode and allows the fan to start	10°C - 25°C	Temperature sensor on the pipe - below this value, the system switches to cooling mode / allows the fan to start	10°C
P18	In a 2-pipe system, above this value the system switches to heating mode and allows the fan to start	27°C - 40°C	Temperature sensor on the pipe - above this value, the system switches to heating mode / allows the fan to start	30°C
P19	Cooling mode switching ON delay	0-15 min.	Parameter used in 4-pipe systems with automatic switching between heating and Cooling. This avoids switching between modes too often heating and cooling as well as room temperature oscillations	0 min.
P20	Maximum floor temperature	5°C - 45°C	In order to protect the floor, heating will be switched on, when the temperature of the floor sensor exceeds the maximum value	35°C
P21	Minimum floor temperature	5°C - 45°C	In order to protect the floor, heating will be turned off, when the temperature of the floor sensor drops below the minimum value	10°C
P22	Backlight brightness	0% - 100%	Adjustable in the range from 10 to 100%	30%
P23	PIN Code for installer parameters	NO	Function disabled	NO
		PIN	Function enabled	
P24	Require a PIN to unlock the keys every time (function active when P23=PIN)	NO	NO	NO
		YES	YES	
FAN	Fan	NO	Inactive - the output contacts for fan control are completely disabled	YES
		YES	Enabled	
CLR	Clear settings factory reset	NO	No action	NO
		YES	Factory reset	

Installer parameters - RS-485 communication settings

Pxx	Function	Value	Description	Default value
Addr	MODBUS Slave device address (ID).	1 - 247	MODBUS Slave Address (ID)	1
BAUD	Bitrate (Baud)	4800	Bitrate (Baud)	9600
		9600		
		19200		
		38400		
PARI	Parity bit - sets data parity for error detection	None	Lack	None
		Even	Even	
		Odd	Odd	
STOP	Stop bit	1	1stop bit	1
		2	2 stop bit	

Modbus RTU features 8-bit data coding.

The MODBUS RTU structure uses a master-slave system to exchange messages. It allows the connection of maximum of 247 slaves, but only one master. The master controls the operation of the network and only it sends the request. The slaves do not undertake the transmission themselves. Each communication starts with making a request by the master to the slave, which responds to the master with what it has been asked. The master (computer) communicates with the slaves (controllers) in two-wire RS-485 mode. For this purpose data exchange uses data lines A+ and B-, which MUST be one twisted pair.

WARNING:

Before the controller is connected to the RS-485 network, it must first be correctly configured. **Communication parameters and descriptions of MOD-BUS registers are available in the appendix on the product website www.engocontrols.com.**

Factory reset

To RESET controller to factory settings, hold down the & buttons until the FA message appears. Then release the keys. Controller will restart, restore default factory settings and displays the home screen. The device will be also removed from app. Factory reset can be done within 5 minutes after power supply connection. If controller is connected longer - factory reset cannot be performed.

