

Wi-Fi, MODBUS Thermostat



Quick Guide

Ver. 1.2
Release date: VIII 2025
Soft:
Main module: v2.0.2
MCU: v0.4.5

Works with
ENGO SMART App
GET IT ON
Google Play
Available on the
App Store

Powered By
tuya

Hey Google works with alexa

Producer:
Engo Controls sp. z o.o. sp. k.
Rolna 4
43-262 Kobielice
Poland

www.engocontrols.com

Product Compliance

This product complies with the following EU Directives: 2014/30/EU, 2014/35/EU, 2014/53/EU, 2011/65/EU.

SAFETY INFORMATION

Use in accordance with national and EU regulations. Use the device only as intended, keeping it in a dry condition. The product is for indoor use only. Please read the entire manual, before installation or use.

Installation:

Installation must be performed by a qualified person with appropriate electrical qualifications, in accordance with the standards and regulations in force in a given country and in the EU. The manufacturer is not responsible for non-compliance with the instructions.

WARNING:

For the entire installation, there may be additional protection requirements, which the installer is responsible for.

Connection description

a) Connection diagram for heating source

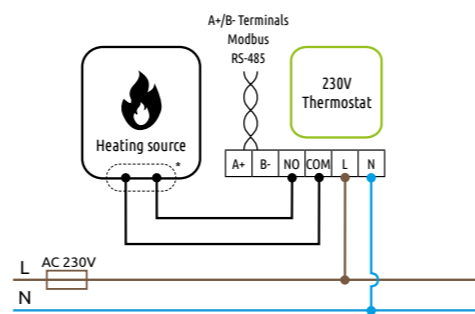

b) Connection diagram for pump / actuator

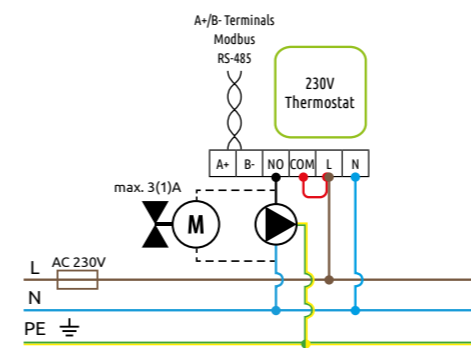

c) Connection diagram to the control box

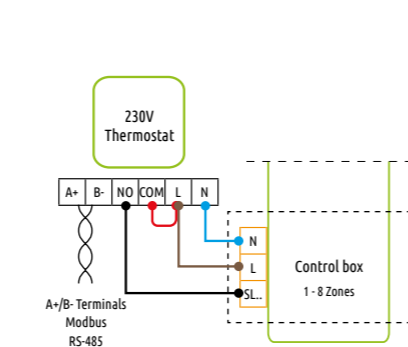

Legend:

- Heating source - Boiler connection*
Boiler's contacts for ON/OFF thermostat (according to the boiler's instructions)
- Pump
- Valve
- L, N** Power supply
- COM, NO** Voltage-free output
- A+, B-** Modbus RS-485 terminals
- SL..** 230V control input in the control box
- Fuse

Installation of the Wi-Fi thermostat in the app

Make sure your router is within range of your smartphone. Make sure you are connected to the Internet. This will reduce the pairing time of the device.

STEP 1 - DOWNLOAD ENGO SMART APP

Download the ENGO Smart app from Google Play or Apple App Store and install it on your smartphone.



STEP 2 - REGISTER THE NEW ACCOUNT

To register a new account, please follow the steps below:

- 1** Click „Sign Up“ to create new account.
- 2** Register
Enter your e-mail address to which the verification code will be sent.
- 3** Enter Verification Code
Enter the verification code received in the email. Remember that you only have 60 seconds to enter the code!
- 4** Set Password
Then set the login password.

STEP 3 - CONNECT THE THERMOSTAT TO WI-FI

After installing the app and creating an account:

- 1** On your mobile device, make sure the ENGO Smart has access to permissions (Location, Bluetooth, Nearby devices). Then turn on Bluetooth and Location. Connect to 2.4GHz Wi-Fi network to which you want to assign the device.
- 2** Make sure the thermostat is powered on. Then press and hold the buttons on the thermostat for approx. 3 seconds until the display shows „PA“. Then release the keys. The pairing mode will be started up.
- 3** In the app, select: „Add Device“.
- 4** After finding the thermostat, go „Add“.
- 5** Select the Wi-Fi network in which the thermostat will operate and enter the password of this network.
- 6** Wait for the app to configure the thermostat with the selected Wi-Fi network
- 7** Go „DONE“
- 8** The thermostat has been installed and displays the main interface.

Introduction

An internet, flush-mounted temperature controller that enables energy-efficient control of heating (any type) and cooling. Designed to be controlled wirelessly over a Wi-Fi Internet network or by wires over RS-485 Modbus communication protocol. Can operate according to user settings stored in the ENGO Smart mobile app, which allows control of device parameters from anywhere in the world (e.g. selection of min. and max. set temperature, key lock). Without connection to the app, it works as a non programmable thermostat.

Products features

- Modbus RS-485 communication
- compatibility with the ENGO Smart application (in Tuya Cloud technology)
- Wi-Fi 2.4 GHz communication standard
- TPI algorithm ideal for underfloor heating
- voltage-free output
- possibility to set the minimum and maximum setpoint temperature range
- cooling mode
- control of underfloor heating or heat source

Technical data

Power supply	230V AC 50 Hz
Max current	3(1)A
Setpoint temp.range	5,0°C to 45,0°C
Display temp. accuracy	0,1°C
Control algorithm	TPI or Hysteresis (±0,1°C to ±2°C)
Communication	Wi-Fi 2,4GHz
Input A+/B-	Modbus RS-485
Output control	COM / NO (voltage-free)
Protection class	IP30
Dimension [mm]	86 x 86 x 39 mm (14 after mounting in a box with a diameter of 60)

LCD icon description + Button description

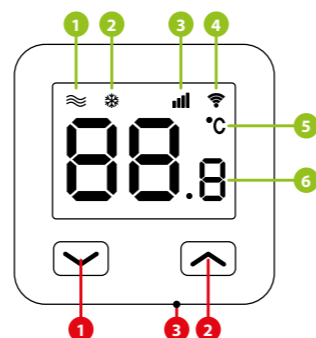

- 1.** Heating mode
 - 2.** Cooling or frost protection mode
 - 3.** Connection with Internet
 - 4.** Connection with Wi-Fi
 - 5.** Temperature unit
 - 6.** Current / setpoint room temperature
- 1.** „DOWN“ button
 - 2.** „UP“ button
 - 3.** „RESTART“ button

	Change the parameter value up
	Change the parameter value down
	Enter the pairing mode - hold until the PA message appears
	Factory reset - hold until the FA message appears.
	Intensity of the night LCD backlight (Ambient Backlight) - hold until Ab message appears, then release the keys and choose the intensity in the range of 0 - 10
	Pressing this key will restart the thermostat (the button should be clicked with a pin)

Ambient backlight

Ambient Backlight is a subtle LCD backlight very helpful in darkened rooms. The subtle glow provides a room temperature reading in nighttime conditions.

General information about MODBUS RTU

The MODBUS RTU structure uses a master-slave system to exchange messages. It allows a maximum of 247 slaves to be connected, but only one master. The master controls the operation of the network and only it sends the request. The slaves do not undertake the transmission themselves. Each communication starts with the master making a request to the Slave, which responds to the master with what has been asked of it. The master (computer) communicates with the slaves thermostats in two-wire RS-485 mode. This uses data lines A+ and B- for data exchange, which MUST be one twisted pair



No more than two cables can be connected to each terminal, ensuring that a 'Daisy Chain' (in series) or 'straight line' (direct) configuration is used. Star or network (open) connection is not recommended as reflections within the cable can cause data corruption.

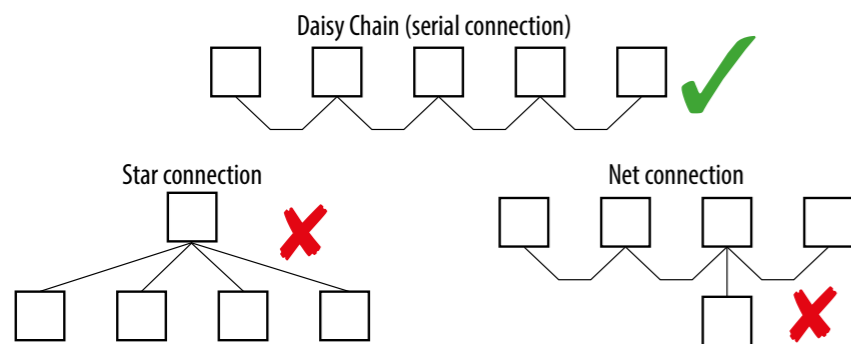

MODBUS RTU network operation - Slave mode

The ENGO MODBUS controller has the following characteristics when operating as a slave device in a MODBUS RTU network:

- Network connection via RS485 serial interface.
- Address, communication speed and byte format defined by hardware configuration.
- Allows access to all tags and data used in the controller ladder program.
- 8-bit slave address
- 32-bit data size (1 address = 32-bit data return)
- each MODBUS data register has a size of 2 bytes.

ATTENTION:

Before the controller is connected to the RS-485 network, it must first be properly configured.

The controller's communication parameters can be set in two ways:

- through configuration from the ENGO Smart application
- or by connecting it to a MASTER computer (e.g. via a USB/RS-485 converter)

ATTENTION:

Connecting unconfigured controllers to the RS-485 network results in their incorrect operation.

RS-485 communication settings of the controller in the app

To access Modbus settings in the controller, follow these steps:

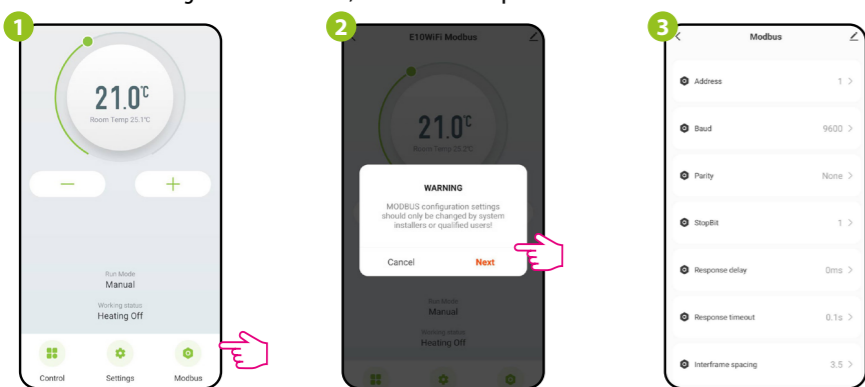

In the application select: „Modbus“.

Confirm with „Next“.

In Modbus settings you can edit the parameters.

RS-485 communication settings

Parameter	Description	Value	Default value
Address	MODBUS Slave device address (ID).	1-247	1
Baud	Baud	1 = 4800 2 = 9600 3 = 19200 4 = 38400	2
Data	Data bites	8 bits	8
Parity	Parity bit - sets data parity for error detection	0 = lack 1 = even 2 = odd	0
StopBit	Stop bits	1 = 1 stop bit 2 = 2 stop bit	1
Response delay	The minimum time from when a slave receives a request until it returns a response. This makes it possible to send data to free masters without overloading the recipient.	0-255 ms.	0
Response timeout	The maximum time to wait to receive a response from the slave device.	0,1-25,5 seconds	10
Interframe spacing	At least 3.5 characters (28 bits) of silence between frames.	3,5-25 signs	3.5

E10 MODBUS supports the following function codes:

- #03 - reading n registers (Holding Registers)
- #04 - reading n registers (Input Registers)
- #06 - write 1 register (Holding Register)

INPUT registers - read only

Adress	Access	Description	Value range	Means	Default
1	R (#03)	Firmware Version	0x0001-0x9999	0x1110=1.1.10 (BCD code)	
2	R (#03)	Working state		0b00000000=Idle, switch OFF 0b10000001=Heating 0b10000010=Heating & Frost protection 0b10001000=Cooling 0b00001000=Idle, sensor error	0xff
3	R (#03)	Value of the Integrated temperature sensor, °C	50 - 450	N-> temp=N/10 °C	
12	R (#03)	Fault information	0,1,2	0 - No alarm 1 - No connection to the cloud 2 - No connection to Wi-Fi network	0
13	R (#03)	Alert message - problems with the internal temperature sensor	0,1,2,3,4	0 - No alarm 1 - Temperature measured below 5C (LO) 2 - Temperature measured above 45C (HI) 3 - Short circuit in the internal temperature sensor circuit 4 - break in the internal temperature sensor circuit	0

HOLDING registers – for reading and writing

Adress	Access	Description	Value range	Means	Default
0	R/W (#04)	Engo MODBUS - online ID number	1-247	ID	1
257	R/W (#06)	Power on/off	0,1	0=OFF 1=ON	1
258	R/W (#06)	Operation mode	0,1,2,3	0=Manual mode 1=Program mode 2=Holiday mode 3=Frost mode	0
262	R/W (#06)	Child lock	0,1	0=Unlocked 1=Locked	0
263	R/W (#06)	Backlight brightness	0-100	N-> Brightness=N%	60
264	R/W (#06)	Ambient Backlight Level	0-10	N-> Bridgness=N%	0
265	R/W (#06)	Control type	0-10	0 = TPI UFH, 1 = TPI RAD, 2 = TPI ELE, 3 = Histeresis 0.2 (+/-1C).... ... 10 = Histeresis 4.0 (+/-2C)	0
268	R/W (#06)	Clock minutes	0-59	Minutes	0
269	R/W (#06)	Clock hours	0-23	Hours	0
270	R/W (#06)	Clock Week Day (1=Monday)	1~7	Week day	3
273	R/W (#06)	Setpoint temp in program mode	50-450	N-> temp=N/10 °C	210
274	R/W (#06)	Setpoint temp in manual mode	50-450	N-> temp=N/10 °C	210
275	R/W (#06)	Frost protection setpoint	50	N->temp=N/10 °C	50
279	R/W (#06)	Max setpoint temp	50-450	N-> temp=N/10 °C	350
280	R/W (#06)	Min setpoint temp	50-450	N-> temp=N/10 °C	50
285	R/W (#06)	Offset temperature	-35...35	N-> temp=N/10 °C (-3,5...3,5 °C in steps of 0,5°C)	0
287	R/W (#06)	Relay type	0,1	0 = NO 1 = NC	0
288	R/W (#06)	Heating/Cooling Selection	0,1	0 = Heating 1 = Cooling	0

Factory reset

To RESET Thermostat to factory settings, hold down the & buttons until the FA message appears. Thermostat will restart, restore default factory settings and displays the home screen. The device will be also removed from app. Factory reset can be done within 5 minutes after power supply connection. If thermostat is connected longer - factory reset cannot be performed.

