



**HEATING CONTROL  
SIMPLE AS NEVER!**

**INSTALL**

**SIMPLY!**

**PRODUCT CATALOG 2024**



## About our company

We are a modern brand in the heating control industry. Our technicians take a close look at the heating market. We know its strengths and weaknesses. We know what customers want. We know what problems they encounter during the winter season. We create devices which solve those problems.



## Our values

We want to provide our customers with convenience with minimal impact on nature. We focus on ecological responsibility and proven technologies.

*We believe that technology is for people - never the other way around*

## What makes us different?

### Energy efficiency

Heating control saves energy. We use only as much as we need. As a result, the house is always optimally heated and the bills are lower.



### New solutions

We use only modern, efficient technology in our devices. We are also open for cooperation with other future automations (Tuya Cloud).



### Guarantee

When designing products, we pay attention to details. We test, check and control the quality and functionality of our products. This allows us to offer a long warranty period and free advice before and after purchase as standard.



### Opportunities









We are moving in an eco-friendly direction. Less energy consumption helps the environment. Our equipment - thanks to its efficiency - gives an opportunity to relieve the burden on nature.





## ENGO Controls - user benefits

We want to provide solutions that fit your lifestyle. We are here to ensure you feel great in your own home.

- |  |  |   |   |
|--|--|---|---|
|  | Comfortably heated interiors                                 |  | 5-year product warranty, at no extra charge                 |
|  | Savings in the household budget                              |  | Trouble-free service  |
|  | High-quality manufacturing and operations of control devices |  | Increase in property value                                  |
|  | Is fully automatic and long-lasting                          |  | Our system is easy to operate with well-thought functioning |

*We want our products to be a part of your pleasant home atmosphere*

## ENGO Smart

**ENGO Smart** app is based on the world famous Tuya Cloud system for controlling devices in a smart home. Its greatest advantage is versatility: it supports many products of many various brands. In one app you can control devices of different types.

For example:

- heating system
- bulbs, lamps, LED stripes
- light and power switches
- window roller blinds, garage doors
- alarm sensors, cameras
- domestic appliances and devices

The advantages are enormous! You can choose from thousands of different offers, decide on the type and brand of product, and then combine everything into a system operated by a single app **ENGO Smart** in Tuya Cloud.

## Universal smart home

ENGO Controls devices adapt to the needs of each building. In connection with each other, they create a reliable and modern heating control system.

We offer both products working in a Wi-Fi network (communication through a router), as well as working with the ZigBee 3.0 protocol, where communication is done via an Internet gateway.

ENGO Smart app provides remote control of devices. The ZigBee network via the Internet gateway keeps the created rules working even when the Internet connection is missing.

The application allows building automatic action sequences. Devices turn on or off depending on: the designated time, sunrise/sunset, temperature, signal received from another device.

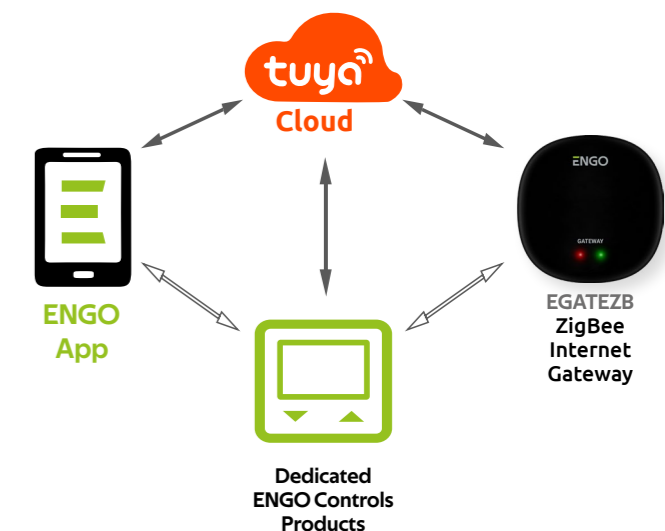

## ENGGO Controls - benefits for the installer

We value installers and respect their time. Therefore, we take special care that the cooperation in the field of installation and commissioning of our systems is the best.



Individual approach to each installation



Increased number of orders: the client regularly expands the system



Assigned mentor for a given investment



Skill growth: technical assistance and training for the installation team



Quick, direct contact with the technical department



Marketing support for companies cooperating with ENGGO Controls



Complies with EU Directive (CE Certificate)



We are open to global technologies (Tuya Cloud)



## The advantages of heating control - it's worth trusting us!

### Saving energy

The heating control system reduces energy consumption to the necessary minimum. Only the minimum required amount of heating fuel is used to heat the building - all according to the needs and individual decisions of residents. As a result, winter bills can be lower and the environment less polluted. It is worth remembering that economy goes hand in hand with ecology. Lower emissions of harmful combustion products into the atmosphere means cleaner air. The fight against smog starts in our homes and it's most effective there.

### A properly heated home

Thanks to clever heating control, the room temperature is set by the occupants. This is ensured by practical heating schedules and the so-called ZONE CONTROL. Remember that if heating of a building is based on measurements from only one room (e.g. living room, where the thermostat has been installed), the temperature in other rooms is always random. This is neither efficient nor comfortable. ZONE CONTROL solves this problem - it allows you to manage the heat of each room separately.

### Healthier living

A well heated house is cheaper to maintain, ecological but also much healthier. We gain better mood and greater comfort of living. We do not think about it everyday, but the temperature of the environment has an influence on our functioning. Efficient work, rest, good mood - thermal conditions affect it all. What is more, a proper home microclimate supports the respiratory and circulatory systems, improves the quality of sleep, stimulates concentration. Both overcooling and overheating are unhealthy. ZONE HEATING CONTROL eliminates these negative factors from our lives.

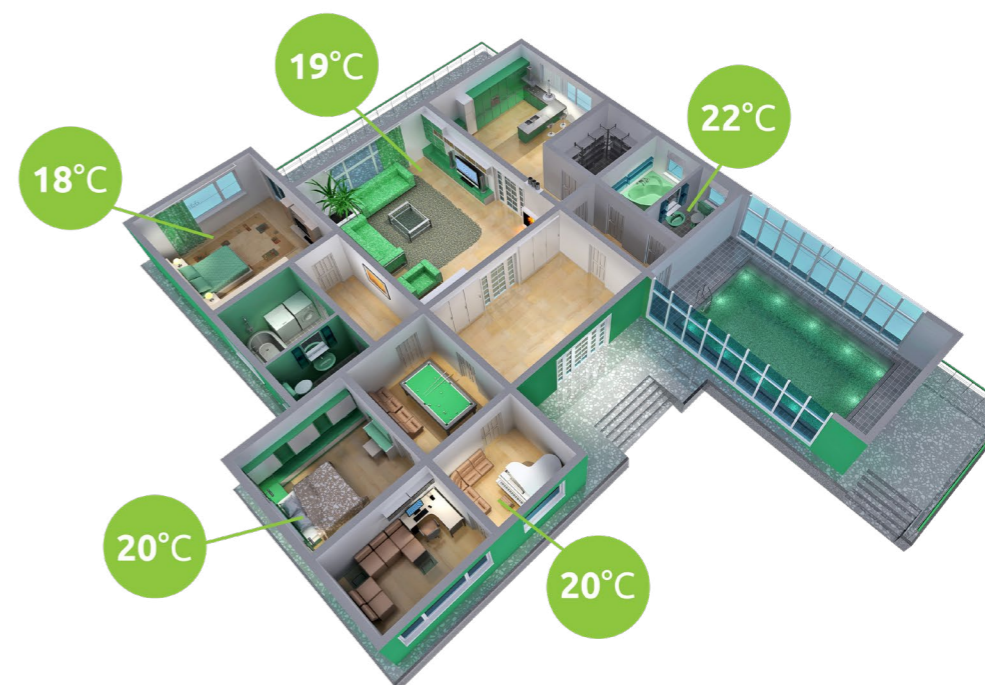



# ENERGY CONTROL IN YOUR HOME

## Types of connections and communications in ENGO CONTROLS

Explore flexible solutions that work with wired and/or wireless technology. In order to best fit your expectations, our products fall into several categories:



**ZIGBEE 3.0**  
Devices operating on the ZigBee protocol. For functioning, the EGATEZB gateway is required.

**WI-FI 2,4 GHz**  
Devices working in the Wi-Fi network (communication via router) providing remote control using ENGO Smart application.

**WIRED**  
Wired devices connected to a control box or to a heating device.



**RF 868 MHz**  
Devices that communicate with each other wirelessly. Data transmission takes place via radio waves.

**MODBUS**  
Devices communicating using the MODBUS RTU (RS485) protocol.

**BOILER CONTROL**  
Devices connected directly to the heat source. You can choose between wired, wireless and Internet thermostats.

## Basic differences between Wi-Fi and ZigBee



WI-FI 2,4GHz

- ✓ No need for an Internet gateway for Wi-Fi device to work.
- ✓ Very fast response time - common refreshing information from the cloud.
- ✓ Wi-Fi protocol is used only in devices powered by 230V.



ZIGBEE 3.0

- ✓ Devices with ZigBee required Internet gateway, thanks to which the devices create a MESH network.
- ✓ Low power consumption allows this protocol to be used in battery-powered devices.
- ✓ The range of wireless communication between devices can be easily increased by adding 230V devices or dedicated signal repeaters.

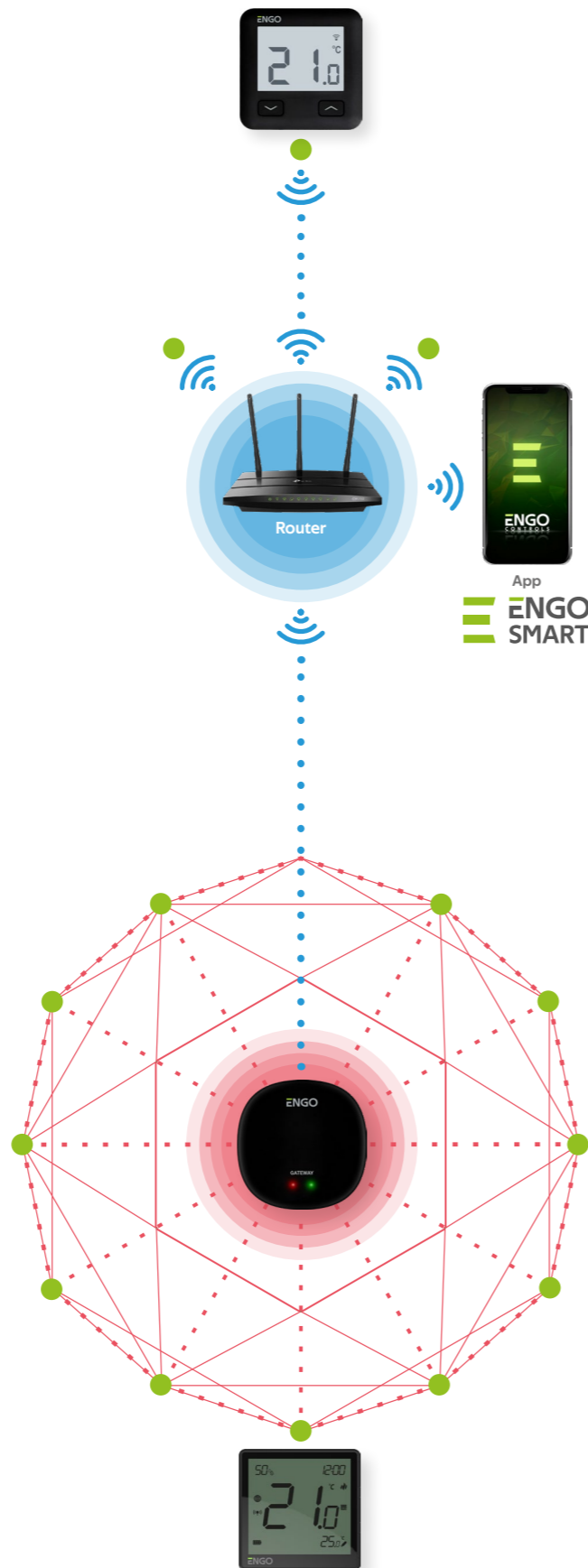

ZIGBEE 3.0



WI-FI 2,4GHz

## ZigBee MESH

ZigBee is a wireless data transmission protocol used for two-way communication between devices. Two-way communication means that each device can both receive and send a signal. The system was created in 2002 by the ZigBee Alliance, which is still involved in its development and promotion. The main features of this communication standard are low power consumption, fast installation, easy operation and stable operation of devices in the MESH network.

**EGATE**  
Universal Gateway ZigBee  
**EGATEZB**  
932341273

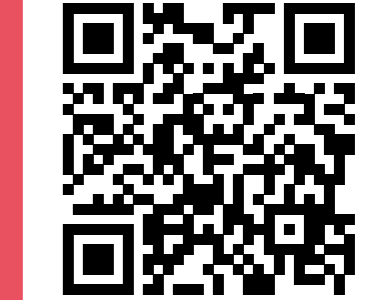

Instructions  
on how to create  
a ZigBee MESH network

Power supply	5V DC micro USB
Communication	ZigBee 3.0 Wi-Fi 2,4GHz
Dimensions [mm]	72 x 72 x 21

EGATEZB is the main component needed to build a smart home system based on devices that will communicate using the ZigBee 3.0 data transmission protocol. The gateway collects data from all sensors, thermostats, actuators and other smart home system components connected to it. It is also responsible for the stability of the rules and created scenarios in the ZigBee network, even when there is no Internet access temporarily. The EGATEZB universal gateway connects to the Internet (router) via a 2.4GHz Wi-Fi network. The gateway is compatible with the ENGO Smart application, where it is possible to make connections between ZigBee devices and Wi-Fi devices (compatible with the application) and create mutual scenarios.

CAUTION: related devices communicating in the ZigBee standard will work without Internet access.

### Product features:



ZigBee 3.0 communication standard



Wi-Fi 2.4 GHz communication standard



works with ENGO Smart  
(Compatible with Tuya App)



LEDs indicating operation status



# ZigBee wired and wireless underfloor heating control

Learn more about our products

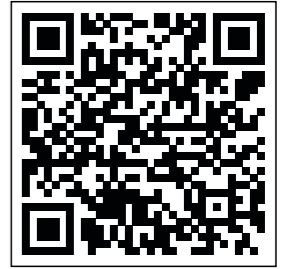

## ZigBee Smart Home elements



WI-FI 2,4GHz

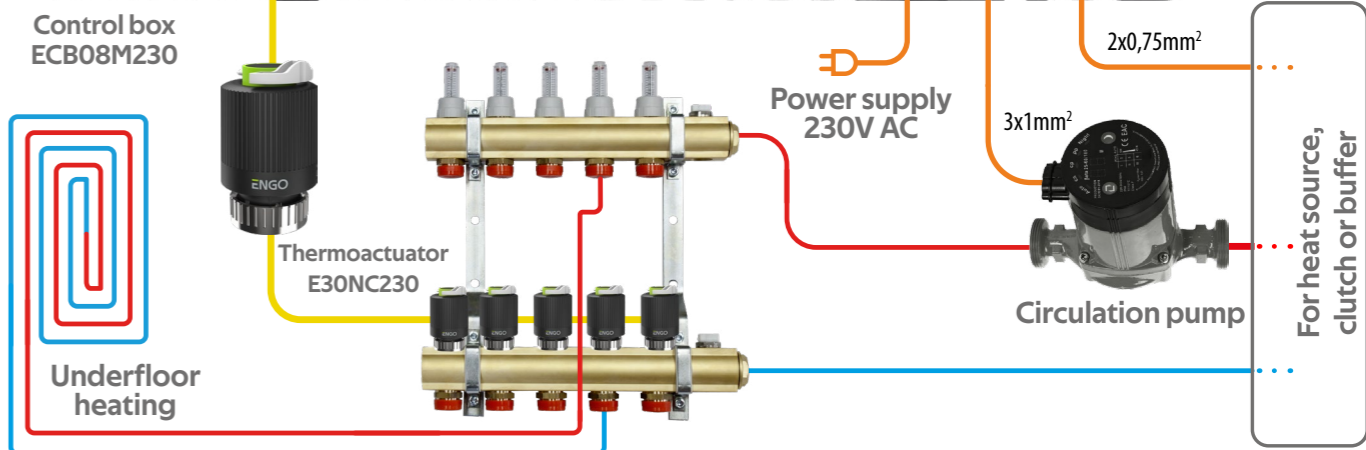
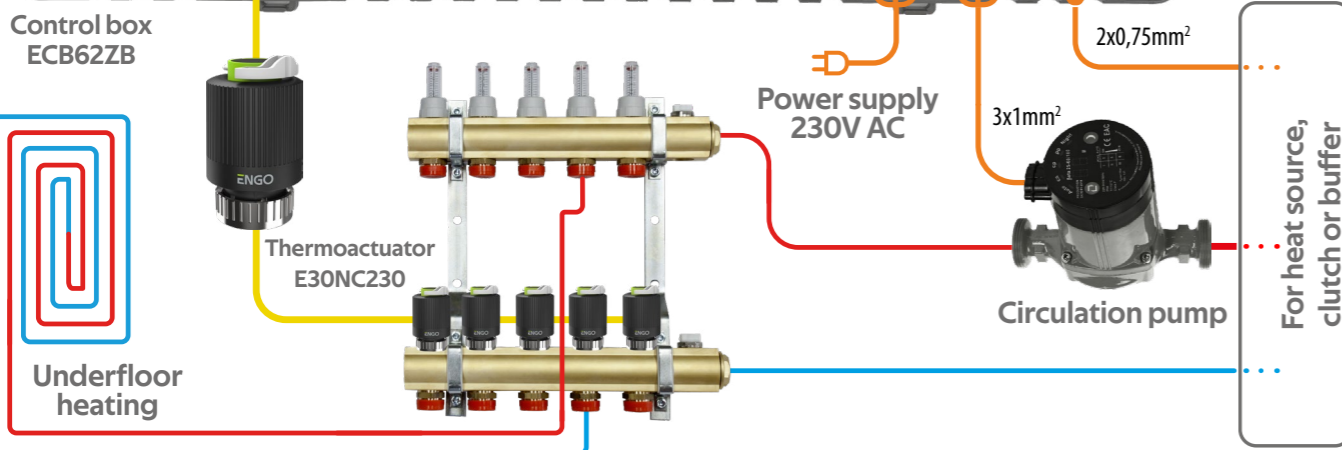
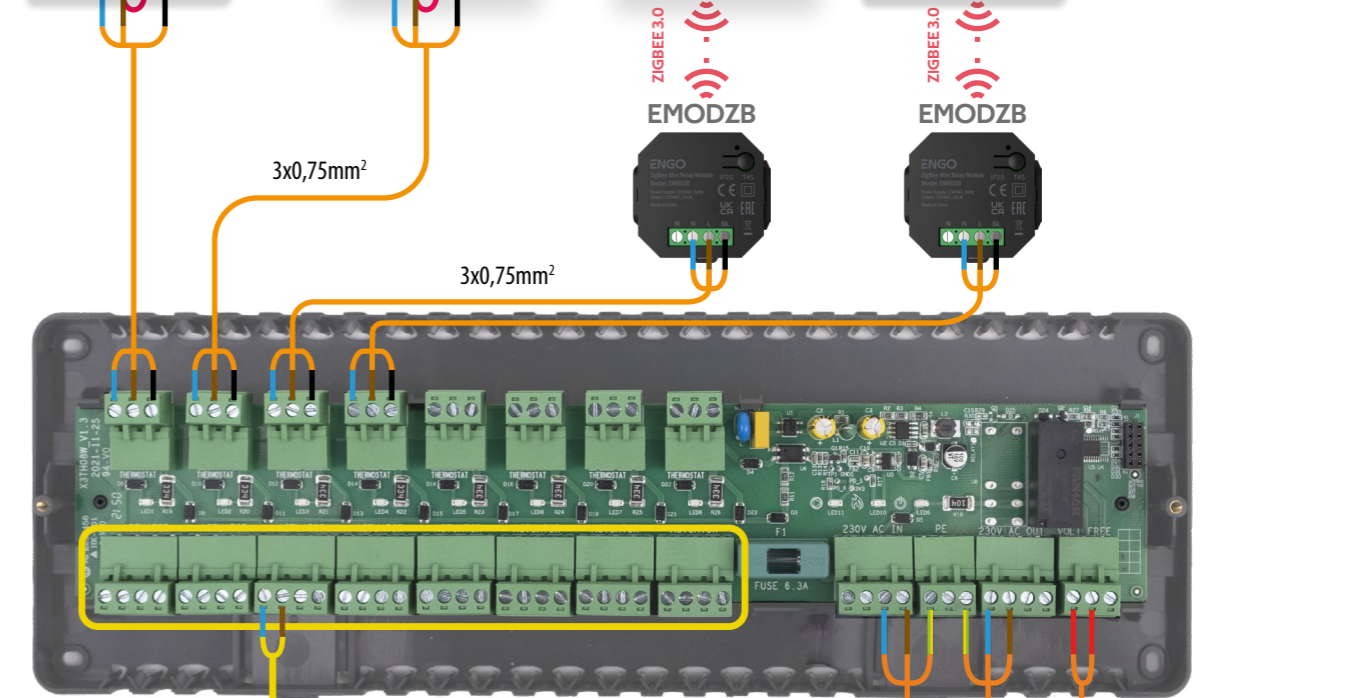
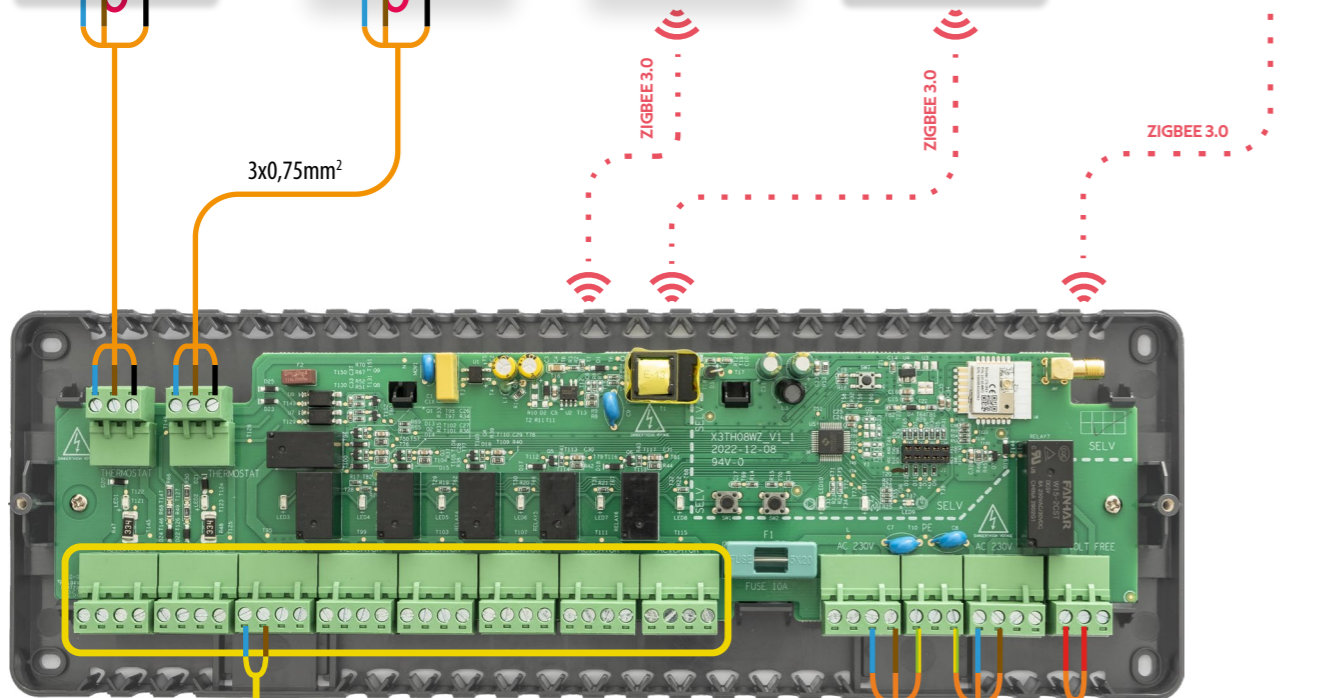

# ONE

## ZigBee Smart Thermostat

### EONE230W / EONE230B

932342631 / 932342632 Flush-mounted 230V version, white / black

### EONEBATW / EONEBATB

932342633 / 932342634 Surface-mounted battery version, white / black



Power supply	230V AC 50Hz
- Flush-mounted	Built-in 3.7V Li-Ion battery
- Surface-mounted	3 (1) A (230v version)
Max current	5 – 45°C
Temp. setpoint range	0.5°C
Display temp. accuracy	TPI
Control algorithm	Hysteresis (±0.1°C to ±2°C)
Communication	ZigBee 3.0 2,4GHz
Input S1-S2	Floor or air temp sensor, hotel card
Control output	NO/COM voltage free (230v version)
Dimensions [mm]	90 x 90 x 34 (13 after mounting in a box with a diameter of 60)
- Flush-mounted	90 x 90 x 14
- Surface-mounted	

ENGO ONE is an innovative temperature thermostat with built-in humidity sensor. It is a combination of modernity with precise operation and interesting design. It is characterized by simplicity of installation and operation. Both the surface-mounted battery version (built-in lithium-ion battery) and the flush-mounted 230V version, can be controlled wirelessly via the ENGO Smart app, using the ZigBee 3.0 EGATEZB gateway. The flush-mounted version is wired directly to the receiver (e.g. a control box). It is mainly designed to control underfloor heating systems.

The ENGO ZigBee series of devices is the only series that works with the Tuya system. It offers ENGO binding function, which allows connecting EONE thermostats to receivers directly (ECB62ZB control box, EMODZB module, EREL1ZB12A relay) using the EGATZB gateway. This allows to connect the devices without the need to create automation in the mobile application. The binding function ensures stable communication of devices online and offline (even without Internet or router connection).

#### Product features:

- works with ENGO Smart (Compatible with Tuya App)
- ZigBee 3.0 communication standard
- ENGO BINDING: ENGO binding function (binding of devices in Online and Offline mode)
- HEATING/COOLING function
- push notifications from the app
- possibility to set the minimum and maximum setpoint temperature range
- adjustable display backlight strength
- possibility of connecting additional NTC sensor
- possibility to share devices with multiple users
- Programmable change of relay type (for 230V powered version)
- very easy to use
- comfort WARM FLOOR function

Choose the best version of the thermostat for you with an ultra-thin design and control your heating...



# CONTROL BOX

## Wireless Control Box for Underfloor Heating System

### ECB62ZB

932341430



Power supply	230V AC 50Hz
Max current	10 (1) A
Communication	wired and wireless ZigBee 3.0
Input	2 wired zones
Outputs	6 ZigBee wireless zones
	Pump (230V)
	Boiler (NO/COM/NC)
Dimensions [mm]	Thermoelectric actuators (230V)
	330 x 110 x 36

Control box allows to control the surface heating. It is equipped with voltage outputs 230V for the circulation pump, thermostats and thermoelectric actuators. The control box allows control of 8 heating zones in a combination of connections - 2 wired and 6 wireless temperature thermostats. It works with NC type actuators, such as E30NC230, E28NC230. The control box has a built-in module for controlling a heating device, e.g. boiler, heat pump (voltage-free output).

Wired control is performed by direct cable connection of thermostats to the control box. The thermostats can be battery operated (COM-NO contact) or powered by 230V AC. Wireless communication is performed in ZigBee 3.0 technology with dedicated temperature thermostats EONEBAT, EONE230 via EGATZB Internet gateway. In addition, by connecting the EGATZB gateway to the Internet, it is possible to control room temperature (EGATZB and ECB62RF compatible thermostats are required) using the free ENGO Smart mobile application. The set with the box includes an antenna with a magnet.

#### Product features:

- works with ENGO Smart (Compatible with Tuya App)
- ZigBee 3.0 communication standard
- ENGO BINDING: ENGO binding function (binding of devices in Online and Offline mode)
- 2 wired inputs, 6 wireless (ZigBee 3.0 network)
- built-in heat source control module (voltage free contact)
- adapted for mounting on a DIN rail
- control of 8 independent heating zones
- voltage output to control the circulation pump
- convenient, removable terminals for easy wire connections
- operation of up to 50 thermoelectric actuators
- 3 min time switching delay, built-in function for pump and boiler outputs
- large selection of compatible regulators

2 zones for 230V wired or battery operated thermostats

6 zones for dedicated ZigBee wireless thermostats

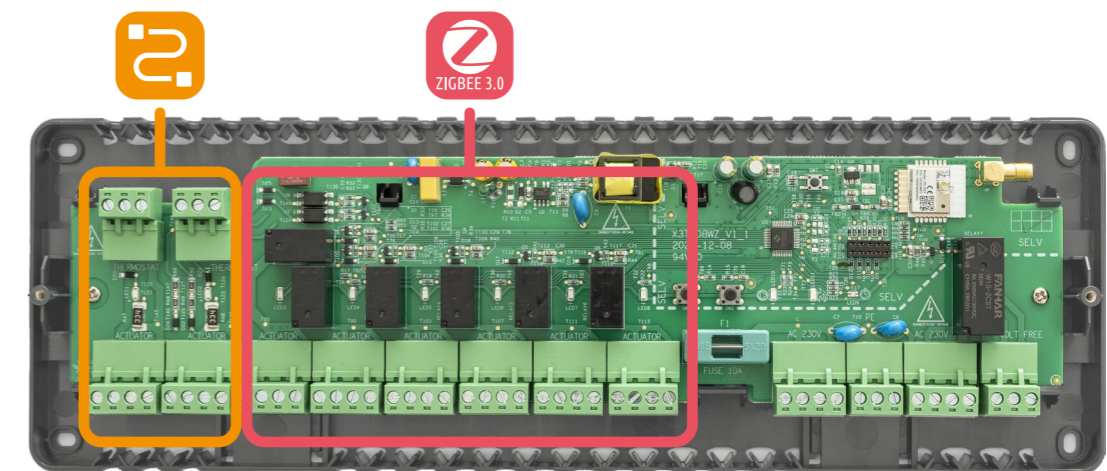



# E20 ZigBee/868MHz Smart Thermostat

## E20W230ZB / E20B230ZB

▶ **AVAILABLE SOON** 932342949 / 932342945 Surface-mounted 230V version, white / black

## E20WBATZB / E20BBATZB

▶ **AVAILABLE SOON** 932342950 / 932342946 Surface-mounted battery version, white / black



Power supply (mains)	230V AC 50Hz
Power supply (battery)	2xAA battery
Max. current	3(1)A (230V version)
Temp. setpoint range	5,0°C - 45,0°C
Display temp. accuracy	0,5°C
Control algorithm	TPI
	Hysteresis (±0,1°C - ±2°C)
Communication	ZigBee 3.0
	RF 868MHz
Control output	COM / NO voltage free (230v version)
Dimensions [mm]	80 x 80 x 23

Surface-mounted temperature controller, used to control underfloor and radiator heating. Easy to install and operate - installer and user friendly. Mains-powered (230V) or battery-powered (2xAA). Programmable and controllable via ENGO Smart application, using ZigBee 3.0 gateway - EGATEZB. The controllers can wirelessly control various ZigBee devices (e.g. wireless ECB62ZB strip, EMODZB module, EREL1ZB12A relay, EREL1ZB16A or ETRV heads). The 230V version also works as a standalone and can be connected directly to a receiver (e.g., a wired control strip).

### Product features:

- works with ENGO Smart (Compatible with Tuya App)
- ZigBee 3.0 communication standard
- ENGO binding function (binding of devices in Online and Offline mode)
- possibility to set the minimum and maximum setpoint temperature range
- wireless communication with TRV heads in the standard 868MHz
- TPI algorithm ideal for underfloor heating

# E TRV Thermostatic Radiator Valve

## ETRVM30W / ETRVM28W

▶ **AVAILABLE SOON** 932330768 / 932250767 Thread size M30 / M28



Power supply	2xAA battery
Communication	Wireless with controllers E20ZB (868 MHz + ZigBee)
Thread size	M30 x 1.5 / M28 x 1.5
Dimensions [mm]	Φ50 x 81

Wireless head is used to control radiator heating. An excellent replacement for the traditional manual thermostatic head. For proper operation of the TRV head, it is necessary to associate it with the E20 master controller. Two-way communication and temperature comparison system provides a sense of comfort throughout the heated area, not just near the radiator. Up to 6 TRV heads can be paired with one controller in the same room.

### Product features:

- works with ENGO Smart (Compatible with Tuya App)
- wireless communication with E20ZB master controller
- automatic calibration
- exceptionally quiet
- plug&play
- small size

# Wireless control ZigBee radiator heating

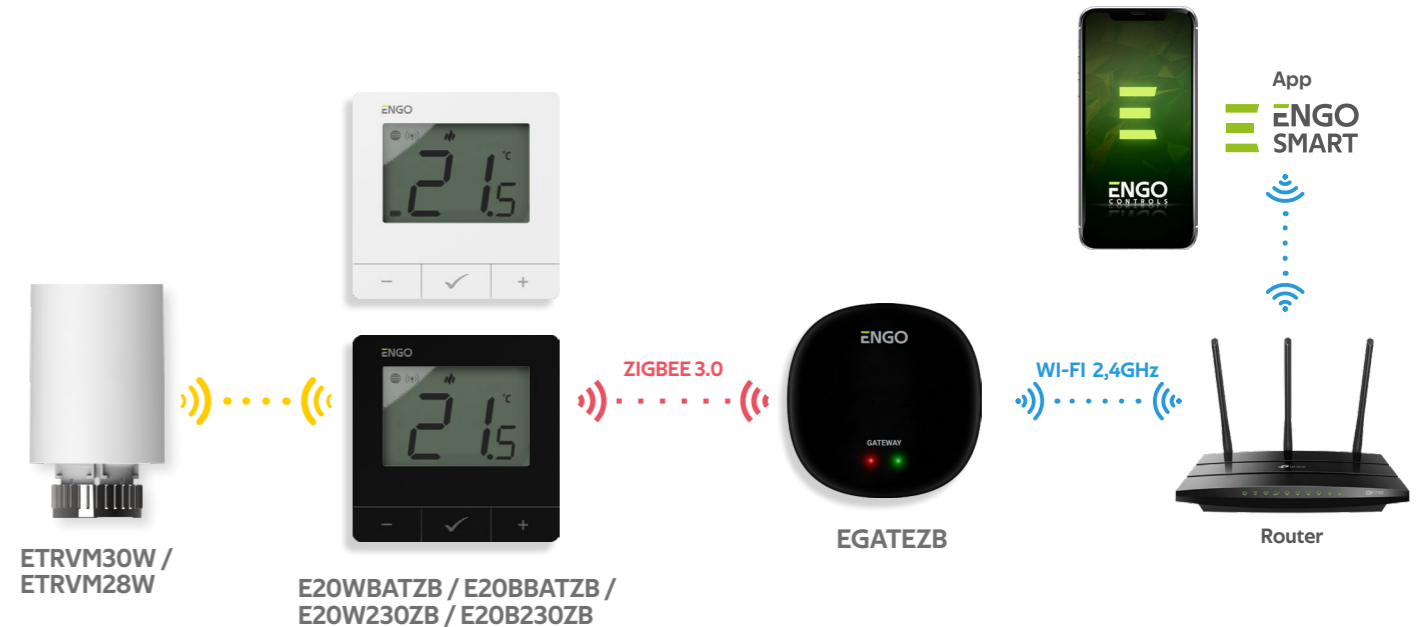

# ERELAY

## ZigBee Relay Module, 12A

### EREL1ZB12A

932343974



Power supply	230V AC 50Hz
Max current	12A
Communication	ZigBee 3.0
Control output	NO/COM (voltage free)
Input	voltage-free contact
Dimensions [mm]	48 x 48 x 20

The product is designed to intelligently control any on/off device. You can use EREL1ZB12A to: opening/closing garage/entry gates, controlling lighting, central heating circulation pump, DHW circulation pump, but also heat source - e.g. gas boiler or heat pump (after configuration with other system components). The relay allows you to set an operating schedule in the ENGO Smart application or build rules in which its switching on/off is dependent on another device (e.g. switching on the lighting when the opening sensor detects an open door). The size of the module allows it to be placed in a flush-mounted installation box.

#### Product features:

- works with ENGO Smart (Compatible with Tuya App)
- ZigBee 3.0 communication standard
- ENGO BINDING ENGO binding function (binding of devices in Online and Offline mode)

# ERELAY

## ZigBee Relay Module, 16A

### EREL1ZB16A

▶ AVAILABLE SOON 932253961



Power supply	230V AC 50Hz
Max current	16A
Communication	ZigBee 3.0
Control output	NO/COM (voltage free)
Input	voltage-free contact or temperature sensor EFS300
Dimensions [mm]	46 x 46 x 24

The product designed to intelligently control any on/off device. It differs from the model EREL1ZB12A maximum load (as high as 16A) and the option to connect the EFS300 sensor available in the offer (temperature reading in the ENGO Smart application allows you to build rules based on its measurement). It allows you to create scenarios - starting or shutting down devices after receiving a signal from another system component, such as an opening sensor (turning on the light when the door is opened). Equipped with a voltage-free output, it allows to control: heat source (e.g. gas boiler), circulation pump, lighting, gates. Mounted in a flush-mounted installation box.

#### Product features:

- works with ENGO Smart (Compatible with Tuya App)
- ZigBee 3.0 communication standard
- ENGO BINDING ENGO binding function (binding of devices in Online and Offline mode)

# ERELAY

## ZigBee Mini Relay Module

### EMODZB

932342371



Power supply	230V AC 50Hz
Max current	3 (1) A
Communication	ZigBee 3.0 2,4GHz
Control output	230V AC
Dimensions [mm]	40 x 40 x 20

The EMODZB wireless module is most often used to convert a wired-controlled zone in an ECB08M230 or ECB62ZB strip to wireless control. It can be paired with EONE or E20 series controllers. The module is a repeater of the ZigBee network - it increases its range. Status of operation is indicated by an LED. The product is mounted flush or on a DIN rail.

#### Product features:

- works with ENGO Smart (Compatible with Tuya App)
- ZigBee 3.0 communication standard
- ENGO BINDING ENGO binding function (binding of devices in Online and Offline mode)

# EROLLER

## ZigBee Roller Shutter

### EROLZB

▶ AVAILABLE SOON 932343964



Power supply	230V AC 50Hz
Max current	2x16(5)A
Communication	ZigBee 3.0
Output SL1, SL2	230V AC 50 Hz
Input S1, S2	230V AC 50 Hz
Dimensions [mm]	46 x 46 x 24

Roller shutter is designed to control the drives of window blinds and curtains in a smart building. It provides trouble-free and smooth operation of even large, demanding motors - the maximum contact load is as high as 16(5)A. The device gives possibility to program selected operating modes using the ENGO Smart mobile application. The controller allows percentage (gradual) opening and closing of window blinds, which improves the comfort of their daily use. It can also be controlled manually, using connected buttons. It works in conjunction with the EGATEZB internet gateway (available separately in the offer).

#### Product features:

- works with ENGO Smart (Compatible with Tuya App)
- ZigBee 3.0 communication standard
- LED indicating operation status

# EREPEATER

## Repeater ZigBee

### EREPEATERZB / EREPEATERMOD

932343975

▶ AVAILABLE SOON 932253962



Power supply	230V AC 50Hz
Communication	ZigBee 3.0
EREPEATERZB dimensions [mm]	40 x 24 x 82
EREPEATERMOD dimensions [mm]	40 x 40 x 20

The device increases the range of the ZigBee 3.0 wireless network in a control system based on ENGO EGATEZB gateway. It is useful where wireless connectivity is weak because of distance or obstacles (concrete walls, reinforced ceilings, etc.). Repeater is an addition to the system and does not work independently. For its proper operation, a ZigBee 3.0 gateway (EGATEZB) is required, available in the offer.

#### Product features:

- wireless communication in ZigBee 3.0 standard
- LED indicating operation status
- minimalistic design

# EDOOR

## ZigBee Door/Window Sensor

### EDOORZB

932343972



Power supply	battery CR2450
Communication	ZigBee 3.0
Dimensions [mm]	72 x 42 x 16

EDOORZB is a battery-operated magnetic sensor, compatible with the ZigBee 3.0 standard. A change in the status of the device automatically sends a signal to a ZigBee Internet gateway (e.g. EGATEZB). It can be used to create rules for the operation of home appliances (scenes) and where you need information about the opening or closing of doors, windows, garage doors, etc. Using the ENGO Smart app, it is possible to create a relation between the window opening sensor and the room temperature thermostat (e.g. if the window is opened, the heating or air conditioning is turned off). The opening is detected based on the distance between the sensor and the magnet. The product is designed for indoor use only.

#### Product features:

- ZigBee 3.0 communication standard
- LED indicating operation status
- minimalistic design



# Wi-Fi wired and wireless underfloor heating control

Learn more about our products



## Wi-Fi Smart Home elements

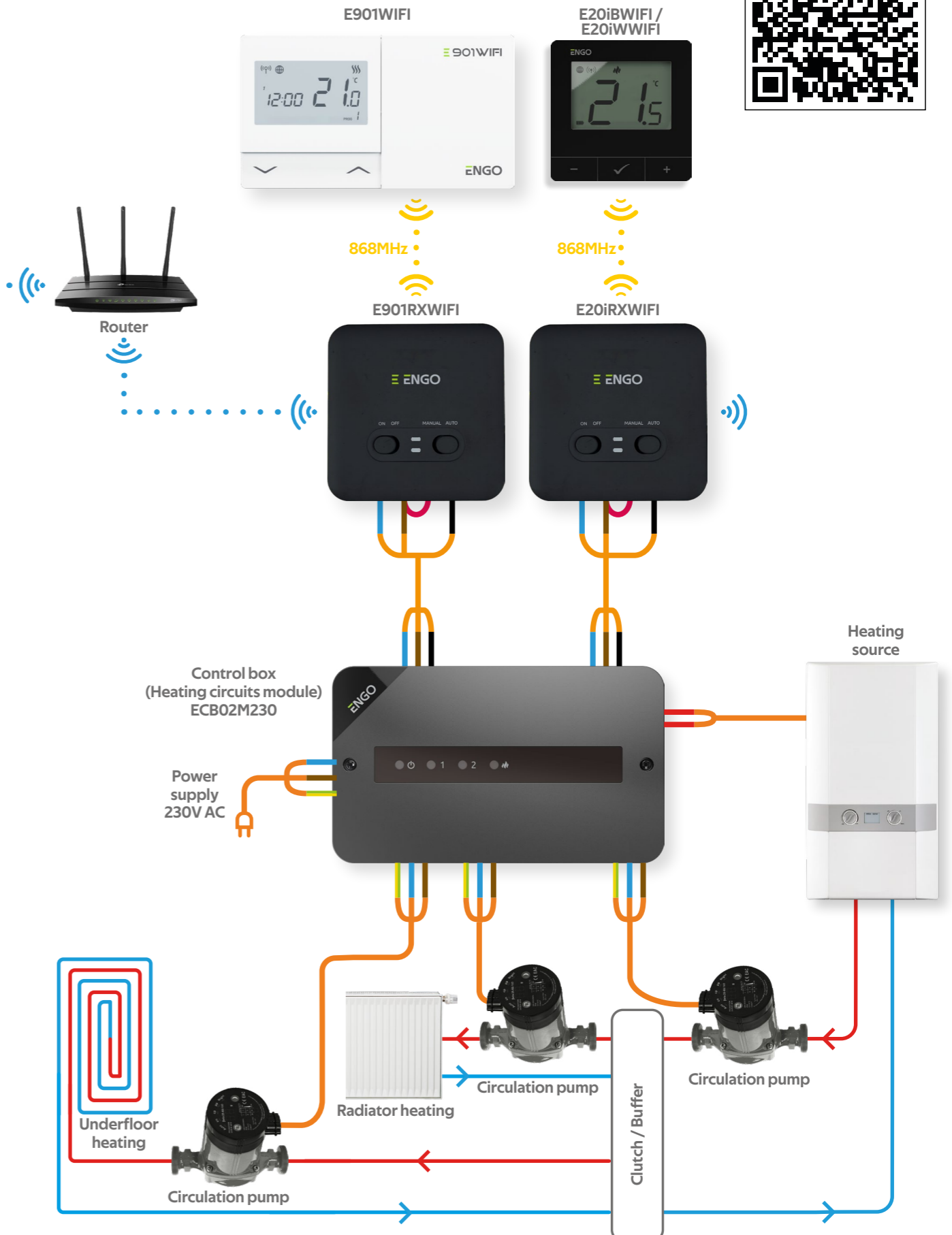
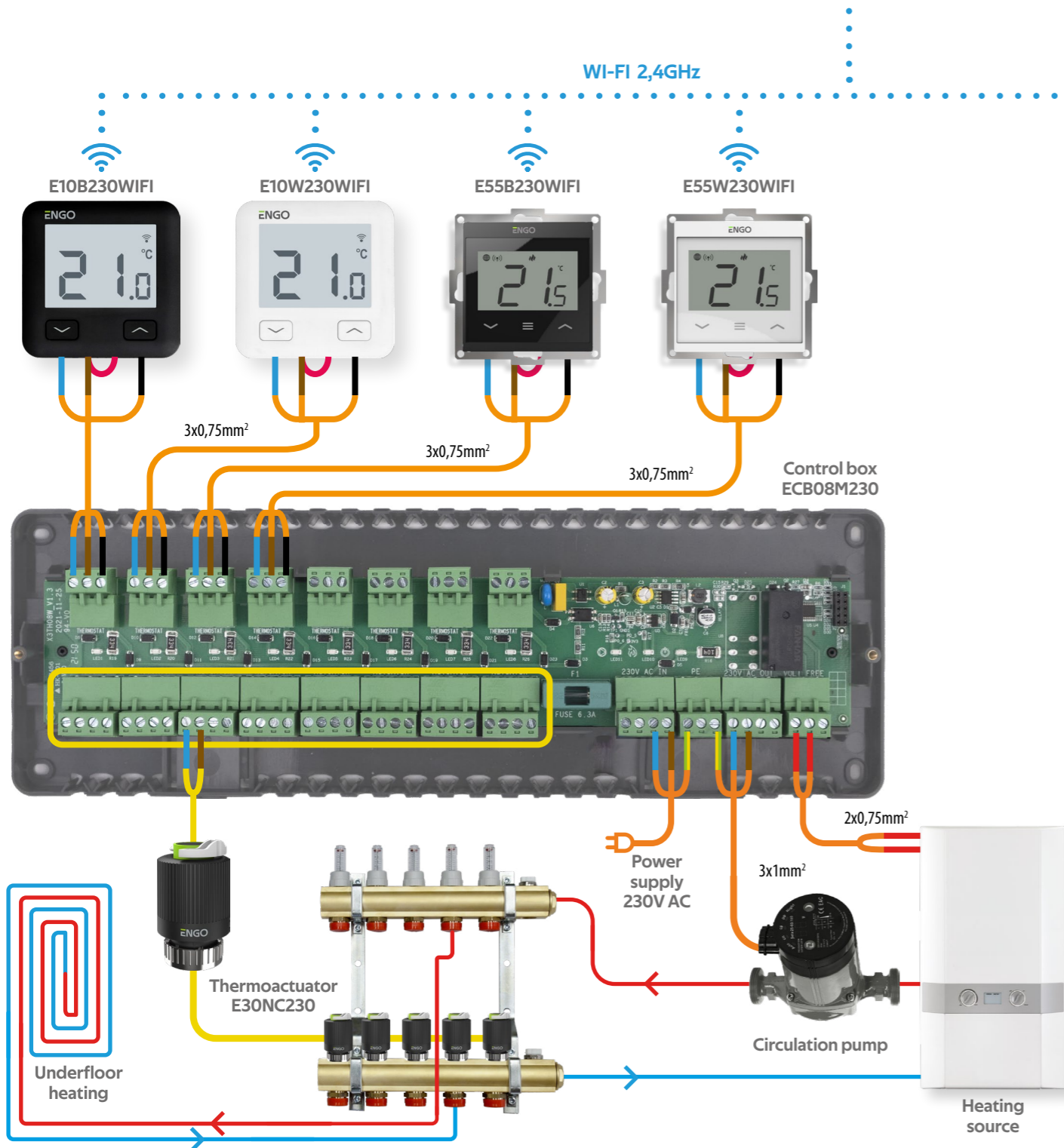



## Wi-Fi Thermostat

**E10W230WIFI / E10B230WIFI**

932312902 / 932312901 white / black



Power supply	230V AC 50Hz
Max current	3 (1) A
Temp. setpoint range	5 – 45°C
Display temp. accuracy	0.1°C
Control algorithm	TPI
	Hysteresis ( $\pm 0.1^\circ\text{C}$ to $\pm 0.5^\circ\text{C}$ )
Communication	WiFi 2,4 GHz
Input S1 and S2	Floor temp. sensor or air temp. measurement
Control output	NO/COM (voltage-free relay)
Dimensions [mm]	86 x 86 x 39 (14 after mounting in a box with a diameter of 60)

E10 is a wired temperature thermostat with a WiFi and Bluetooth module. It enables economic and ecological control of any type of heating. Provides remote control of the heating system using the ENGO Smart application. It is characterized by a clear menu and a multitude of useful functions. Programming the E10 is very simple and allows you to adjust the heating cycle to your daily rhythm. The model is available in white and black.

### Product features:

- works with ENGO Smart (Compatible with Tuya App)
- control of underfloor heating or heat source
- possibility to set the minimum and maximum setpoint temperature range
- very easy to use
- TPI algorithm ideal for underfloor heating
- diagrams with temperature history (available in the app)
- external temperature sensor input
- push notifications from the app
- voltage-free output



## WiFi Thermostat suitable for 55x55 switch frame

**E55W230WIFI / E55B230WIFI**

▶ AVAILABLE SOON 932312952 / 932312951 white / black



Power supply	230V AC 50Hz
Max current	3 (1) A
Temp. setpoint range	5 – 45°C
Display temp. accuracy	0.5°C
Control algorithm	TPI
	Hysteresis ( $\pm 0.1^\circ\text{C}$ - $\pm 2.0^\circ\text{C}$ )
Communication	Wi-Fi 2,4 GHz
Control output	NO/COM (voltage-free relay)
Dimensions [mm]	55 x 55 x 39 (17 after mounting in a box with a diameter of 60)

Flush mounted temperature controller for mounting in 55x55 mm frame. Designed to control surface heating characterized by high thermal inertia. It can also control any other type of heating, as well as cooling systems - according to the user's needs and settings. The built-in Wi-Fi module allows easy installation and operation of the heating system using the ENGO Smart mobile app.

### Product features:

- works with ENGO Smart (Compatible with Tuya App)
- TPI algorithm ideal for underfloor heating
- diagrams with temperature history (available in the app)
- HEATING/COOLING function
- possibility to set the minimum and maximum setpoint temperature range
- possibility to share devices with multiple users
- external temperature sensor input EFS300
- adjustable display backlight strength
- push notifications from the app



## Wireless, Internet Thermostat, Wi-Fi

**E20iWWIFI / E20iBWIFI**

▶ AVAILABLE SOON 932312648 / 932312647 white / black



Thermostat power supply	2xAAA batteries
Receiver power supply	230V AC 50 Hz
Max load of the receiver	16(5)A
Receiver output signal	COM / NO (voltage free)
Temperature control range	5,0°C - 35,0°C
Display temp. accuracy	0,5°C
Control algorithm	TPI
	Hysteresis ( $\pm 0,1^\circ\text{C}$ - $\pm 2^\circ\text{C}$ )
Communication	Wireless 868 MHz Wi-Fi 2,4GHz
Transmitter dimensions [mm]	80 x 80 x 23
Receiver dimensions [mm]	96 x 96 x 27

Included: thermostat transmitter (E20iTXWIFI), thermostat receiver (E20iRXWIFI).

A wireless set for controlling standard heating devices (e.g. gas boilers). It is characterized by: simplicity of construction, intuitive operation using the keys and a large and legible display. The built-in Wi-Fi module enables easy and quick configuration of the device in the ENGO Smart mobile application. The controller can be shared with many users, has a scheduling function and a PIN lock. Factory paired and ready to work.

### Product features:

- works with ENGO Smart (Compatible with Tuya App)
- Wi-Fi 2.4 GHz communication standard
- device has unique transmission codes
- TPI algorithm ideal for underfloor heating
- possibility to set the minimum and maximum setpoint temperature range
- HEATING/COOLING function



## Wireless, Internet Thermostat, Wi-Fi

**E901WIFI**

932322661



Thermostat power supply	2 x AA alkaline batteries
Receiver power supply	230V AC 50Hz
Max load of the receiver	16 (5) A
Receiver output signal	NO/COM voltage free relay
Temperature control range	5 – 35°C
Display temp. accuracy	0.5°C
Control algorithm	TPI
	Hysteresis ( $\pm 0.25^\circ\text{C}$ to $\pm 2.0^\circ\text{C}$ )
Communication	Wireless, 868 MHz WiFi 2,4 GHz
Transmitter dimensions [mm]	150 x 84 x 22
Receiver dimensions [mm]	96 x 96 x 27

Included: thermostat transmitter (E901TXWIFI), thermostat receiver (E901RXWIFI), thermostat stand.

Wireless Wi-Fi thermostat that allows economical and ecological control of any type of heating. It is characterized by a clear menu and a multitude of useful functions. The operation of the thermostat is very simple and allows the user to adjust the heating cycle to the users' daily rhythm. The built-in Wi-Fi module (in the receiver) allows remote control of the heating system with a smartphone or tablet using the ENGO Smart. The devices are pre-paired and ready for operation. The product is factory-paired and ready to work. Each set has unique transmission codes.

### Product features:

- works with ENGO Smart (Compatible with Tuya App)
- Wi-Fi 2.4 GHz communication standard
- device has unique transmission codes
- programmable change of relay type
- HEATING/COOLING function
- automatically renews the operating signal
- PIN lock
- possibility to set the minimum and maximum setpoint temperature range
- TPI algorithm ideal for underfloor heating

# ERELAY

## WiFi Relay Module 16A

### EREL1WIFI16A

▶ AVAILABLE SOON 932313960



Power supply	230V AC 50Hz
Max current	16A
Communication	Wi-Fi 2,4 GHz
Control output	NO/COM (voltage free)
Input	voltage-free contact or temperature sensor EFS300
Dimensions [mm]	46 x 46 x 24

Product designed for intelligent control of any on/off device. The voltage-free output allows you to control devices that require circuit closure or 230V. You can use EREL1WIFI16A to: opening/closing garage/entry gates, controlling lighting, central heating circulation pump, DHW circulation pump, but also heat source - e.g. gas boiler or heat pump (after configuration with other system components). The relay allows you to set an operating schedule in the ENGO Smart application or build rules in which its switching on/off depends on another device (e.g., switching on a light when the opening sensor detects an open door). Permissible load capacity of contacts up to 16A. The product gives the possibility to connect the temperature sensor EFS300 (NTC 10kΩ sensor, sold separately). This allows you to see the measured temperature in the application and create smart scenarios depending on this temperature. The size of the module allows it to be placed in a flush-mounted installation box.

#### Product features:

- works with ENGO Smart (Compatible with Tuya App)
- Wi-Fi 2.4 GHz communication standard
- 230V AC voltage supply - stable operation
- voltage-free output
- minimalistic design
- temperature sensor

# IRDA

## Wi-Fi IrDA Transmitter

### EIRTXWIFI

932313971



Power supply	5V DC micro USB
Communication	Wi-Fi 2,4 GHz
Dimensions [mm]	72 x 72 x 21

EIRTXWIFI is a universal product that can replace a traditional remote control. It allows you to conveniently control various infrared receiving devices, such as TV, decoder, air conditioner, etc. It supports local and remote turning on/off of devices. In addition, using the ENGO Smart mobile app, you can create scenes to, for example, automatically turn on/off the TV or air conditioner (only when Wi-Fi is available).

#### Product features:

- works with ENGO Smart (Compatible with Tuya App)
- Wi-Fi 2.4 GHz communication standard
- device works with most Irda devices on the market
- universal infrared remote control
- minimalistic design
- very easy to use

# EROLLER

## WiFi Roller Shutter

### EROLWIFI

▶ AVAILABLE SOON 932313963



Power supply	230V AC 50Hz
Max current	2x16(5)A
Communication	Wi-Fi 2,4GHz
Control output	230V AC 50 Hz
Input	S1, S2
Dimensions [mm]	46 x 46 x 24

Roller shutter controller with built-in Wi-Fi module, supporting window roller shutter drives and curtains in a smart building. It provides trouble-free operation of even large, demanding motors - maximum contact load is up to 16(5)A. The device provides the ability to program selected operating modes using the ENGO Smart mobile application. It allows for percentage (gradual) opening and closing of window blinds, which improves the comfort of their daily use. Universal, compact, durable product.

#### Product features:

- works with ENGO Smart (Compatible with Tuya App)
- Wi-Fi 2.4 GHz communication standard
- minimalistic design
- powerful relays: 2x16A
- LED indicating operation status
- possibility of installation in a box with a diameter of 60 mm

# SENSOR

## Temperature Sensor

### EFS300

932250442

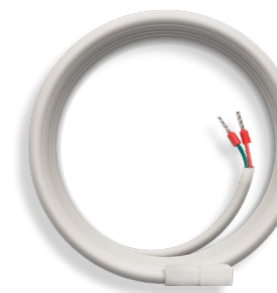

Measuring range	-10° – 100°C
Measuring element	NTC 10kOhm
Cable length	3m
Cross-section	2x0,5mm <sup>2</sup>
Warranty	5 years

EFS300 is a temperature sensor proposed for floor protection against overheating or undercooling in underfloor heating systems. Thanks to its thickness and rigidity, the EFS300 is suitable for installation in the floor. It makes it possible to measure air temperature (transfer of measuring point).

Compatible with thermostats:  
 E10W230WIFI, E10B230WIFI  
 EONE230W, EONE230B  
 EONEBATW, EONEBATB  
 Smart relay EREL1ZB16A, EREL1WIFI16A

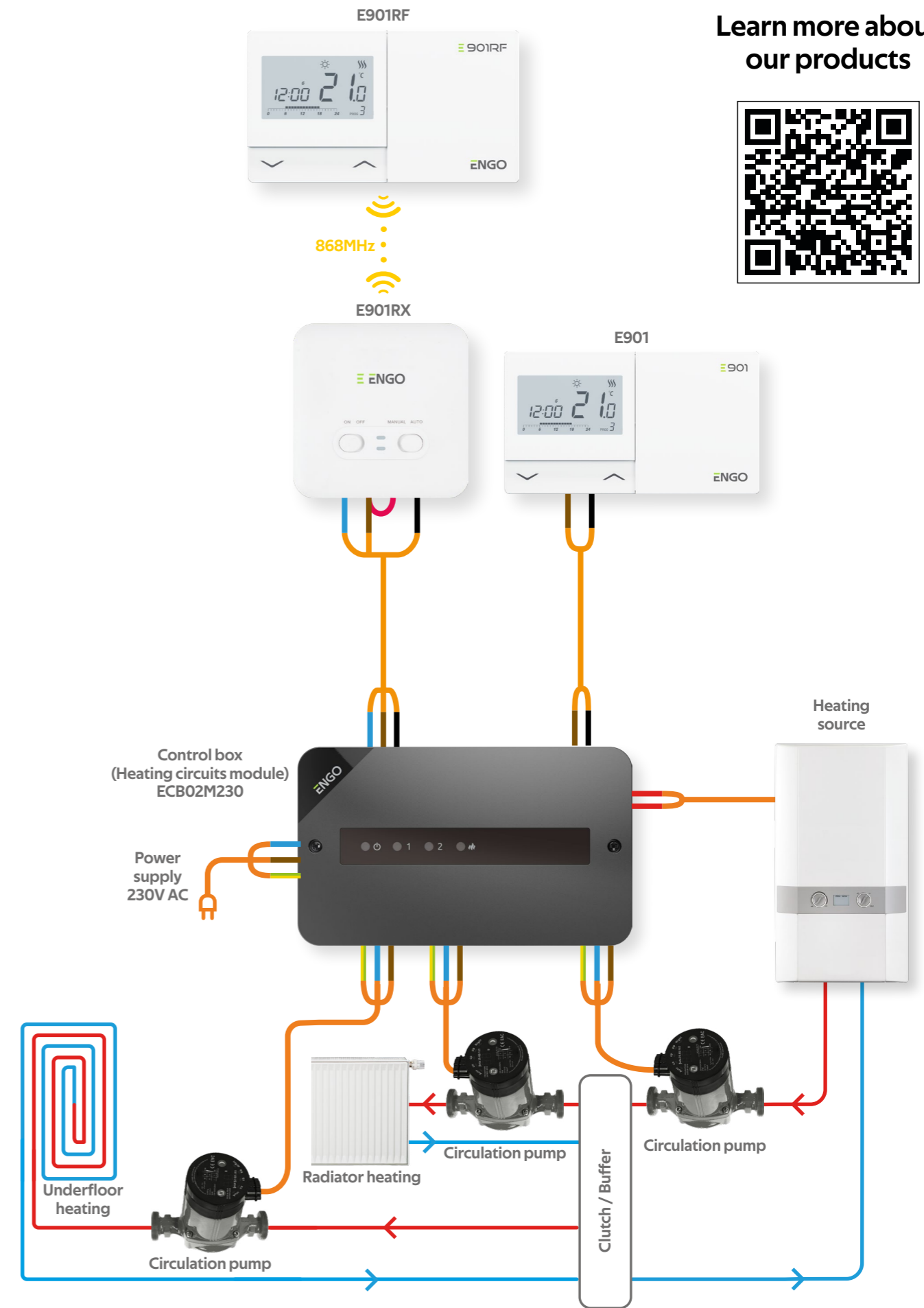
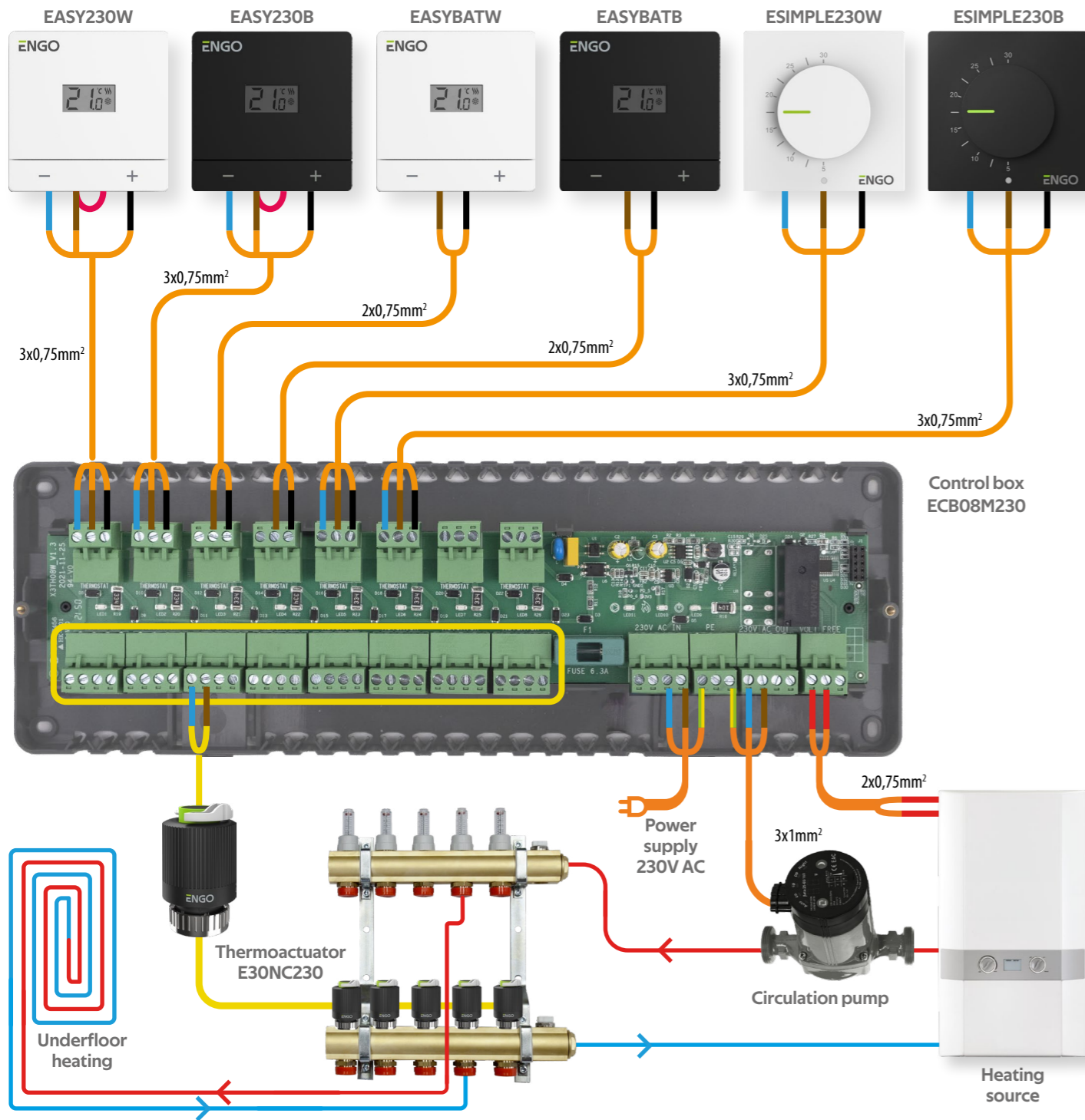

Learn more about our products



## EASY

### Wired Thermostat

**EASY230W / EASY230B**

932332982 / 932332981 230V AC powered, white / black

**EASYBATW / EASYBATB**

932332984 / 932332983 battery-powered, white / black

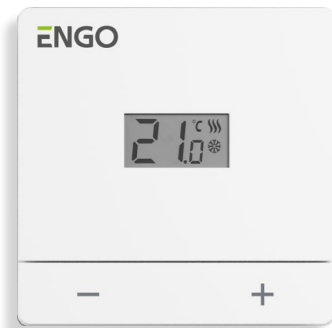

Power supply (mains)	230V
Power supply (battery)	2xAAA batteries
Max current	3 (1) A
Temp. setpoint range	5 – 35°C
Display temp. accuracy	0.1°C
Control algorithm	TPI
	Hysteresis (±0.2°C to ±2°C)
Communication	Wired
Output control (mains)	COM/NO (voltage-free)
Output control (battery)	COM/NO voltage-free output (for e.g. 230V, 24V or 12V systems)
Dimensions [mm]	80 x 80 x 22

Wired temperature thermostat, battery powered (2xAAA) or 230V AC powered. It is used for wired control of heating or cooling devices and systems. It works by maintaining comfortable conditions in the room, in line with the constant temperature set by the user. It is connected directly to a heat source or control box. For a better fit, the model is available in two colors. Safe, reliable, easy to use.

#### Product features:

- minimalistic design
- very easy to use
- key lock function
- control of underfloor heating or a heat source
- voltage-free output
- LCD display
- possibility to set the minimum and maximum setpoint temperature range
- TPI algorithm ideal for underfloor heating
- wired communication
- selectable NO or NC relay type
- hanger for wall mounting included
- HEAT/STANDBY/COOL Switch

### Choose the version for you and control your heating...



Wired thermostat 230V  
EASY230W (White) or EASY230B (Black)

#### ...power supply 230V

The thermostat is powered by 230V power supply. The thermostat is connected by wires to the heating device.



Battery-powered wired thermostat  
EASYBATW (White) or EASYBATB (Black)

#### ...battery power supply

The thermostat is powered by 2xAAA batteries. The thermostat is connected by wires directly to the heating device.

## SIMPLE

### Simple Dial Thermostat 230V

**ESIMPLE230W / ESIMPLE230B**

932332985 / 932332986 white / black



Power supply	230V AC 50Hz
Max current	3 (1) A
Temp. setpoint range	5 – 30°C
Control algorithm	TPI
	Hysteresis (±0.5°C)
Communication	Wired
Control output	230V AC
Dimensions [mm]	80 x 80 x 26

ESIMPLE230B is designed to control surface heating/cooling, characterized by high thermal inertia. Adjustment of the set temperature in a room is made by using a knob. Thanks to built-in algorithms, it offers much better temperature control accuracy than traditional mechanical thermostats.

#### Product features:

- ease of use (knob)
- two-color LED
- TPI algorithm ideal for underfloor heating
- surface mounting
- HEAT / COOL switch hidden under the knob

## BEZEL

### Bezel for thermostats

**BEZELW / BEZELB**

▶ AVAILABLE SOON 932252342 / 932252341 for thermostats EASY, E20, white / black

**BEZEL1W / BEZEL1B**

▶ AVAILABLE SOON 932252340 / 932252339 for thermostats SIMPLE, white / black



Minimalist and elegant frame for surface mounting of temperature controllers. Durable and sturdy. Allows stable installation of the control device, perfectly complementing its design in any interior. Available in white or black.

## CONTROL BOX

### Wired Control Box for Underfloor Heating System, 230V

ECB08M230

932331460



Power supply	230V AC 50Hz
Max current	6 (1) A
Outputs	Pump (230V) Boiler (NO/COM/NC) Thermoelectric actuators (230V)
Dimensions [mm]	330 x 110 x 36

ECB08M230 control box is the main element of the underfloor heating control system. It has a built-box module that controls the heat sources (by volt-free relay) and pump (230V AC). The control box allows to control 8 different zones. It is equipped with 230V AC voltage outputs for actuators. Pluggable terminal blocks provide quick and convenient wiring connections. The control box is designed to work with NC (normally-closed) type actuators.

#### Product features:

- control of 8 independent heating zones
- Volt-Free Boiler control output
- DIN rail holders
- designed for wired thermostats
- 230V Pump control output
- convenient, removable terminals for easy wire connections
- support for up to 50 thermoelectric actuators
- pump & boiler 3min delay start feature
- minimalistic design

## ACTUATOR

### Thermal Actuator, 230V, NC

E30NC230 / E28NC230

932211671 / 932211572



Version	NC = normally closed
Thread size	M30 x 1.5mm / M28 x 1,5mm
Power supply	230V AC 50Hz
Power consumption	2W
Inrush current	300mA / 200ms
Pressing force	100N +/- 15%
Max. stroke	4,5mm
Storage temp.	-25°C / +60°C
Ambient temp.	Max. 60°C
IP protection class	IP 54/II
Power cord length [cm]	90cm
Dimensions [mm]	Φ 41 x 65

The thermoelectric actuator is intended for use with underfloor heating systems. It can be used with thermostatic valves in the manifold for underfloor heating or with zone valves. It allows to open or close the flow of the heating medium in a loop, which gives you the control on the room temperature. It cooperates directly with the thermostat or indirectly via control box.

#### Product features:

- „First Open“ function - makes the first installation easy
- minimalistic design
- big stroke length
- fast opening time
- low power consumption
- modern design, high durability

## CONTROL BOX

### 2 Heating circuits module

ECB02M230

▶ AVAILABLE SOON 932331453

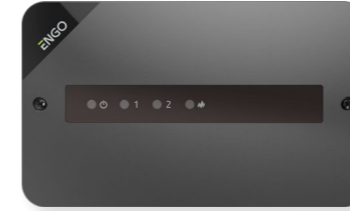

Power supply	230V AC 50Hz
Max current	6(1)A
Outputs	Pump230V AC max. 3(1)A Boiler (NO/COM/NC) max. 6(1)A
Dimensions [mm]	150 x 90 x 35

The heating circuit module makes it possible to operate two independent heat zones to which temperature controllers and circulation pumps are connected. It is used in typical single-family housing, where there are divisions into 2 heating circuits (e.g. 1 first floor circuit and 2 floor circuit). Then the signal coming from any of the heating circuits activates the outputs to the main circulation pump and the heat source in the controller. The integrator can also be used for small (e.g. two-zone) floor heating systems.

#### Product features:

- control of 2 heating circuits
- improvement of plant efficiency
- minimalistic design

## RELAY

### Relay Module 12A

ERM12A

932252541



Power supply	230V AC 50Hz
Max current	12A
Inputs	NO/COM (voltage free) SL 230V AC voltage output signal
Control output	NO/COM/NC (voltage free)
Dimensions [mm]	48 x 48 x 20

It is used for switching on/off electrical devices. Thanks to its small dimensions, it can be installed in an installation box or in any location where it is needed to control a receiver with a maximum load of 12A.

#### Product features:

- LED indicating operation status
- voltage-free output
- minimalistic design

## RELAY

### Wireless Radio Relay

ETR868

▶ AVAILABLE SOON 932253966



Power supply	230V AC 50Hz
Max current	16(5)A
Communication	wireless, 868 MHz
Output control	voltage free NO/COM
Transmitter dimensions [mm]	46 x 46 x 24
Receiver dimensions [mm]	46 x 46 x 24

The set includes: : transmitter (ETR868TX), receiver (ETR868RX), DIN rail mounting brackets.

The set is used for wireless switching of electrical devices (such as pumps, fans, lighting, electric heaters, boiler, etc.). The solution is ideal in the absence of wiring. The product can be used to wirelessly transmit the signal of operation, switching on, off or failure of electrical devices. The transmitter and receiver are factory paired.

#### Product features:

- LED indicating operation status
- voltage-free output
- minimalistic design



# E901

## Programmable, Wired Thermostat

### E901

932322911

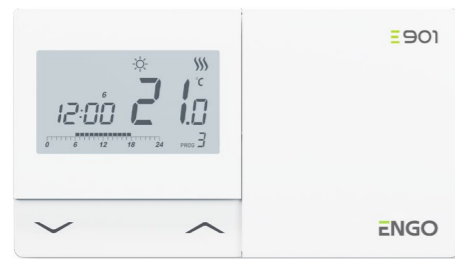

Power supply	2 x AA batteries
Max current	5 (3) A
Output control	COM/NO voltage-free output (For e.g. 230V, 24V or 12V systems)
Temp. setpoint range	5 – 35°C
Display temp. accuracy	0.1°C or 0.5°C
Control algorithm	TPI
	Hysteresis (±0.25°C or ±0.5°C)
Communication	Wired
Dimensions [mm]	150 x 84 x 22

E901 is a programmable, surface-mounted electronic room thermostat, used for controlling of heating devices (e.g. gas, oil boilers, heat pumps) or cooling devices. It allows creating personalised schedules. Thanks to the built-in algorithms, it offers much better temperature control accuracy than traditional mechanical thermostats. The thermostat is connected by wires directly to the heating device.

#### Product features:

- 2 methods of schedule programming
- selectable NO or NC relay type
- TPI algorithm ideal for underfloor heating
- works with HEATING & COOLING Systems
- possibility to set the minimum and maximum setpoint temperature range
- PIN lock
- key lock function
- for Underfloor or Heating Source control

# E901RF

## Programmable, Wireless Thermostat

### E901RF

932322612

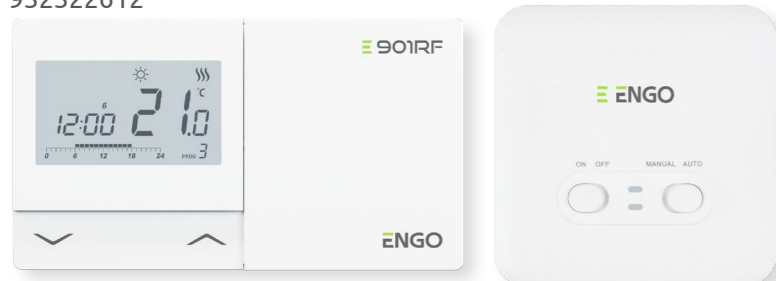

Thermostat supply	2 x AA batteries
Receiver supply	230V AC 50Hz
Receiver's max current	16 (5) A
Receiver's output signal	NO/COM (voltage-free relay)
Temp. setpoint range	5 – 35°C
Display temp. accuracy	0.1°C or 0.5°C
Control algorithm	TPI
	Hysteresis (±0.25°C or ±0.5°C)
Communication	Wireless, 868 Mhz
Transmitter dimensions [mm]	150 x 84 x 22
Receiver dimensions [mm]	96 x 96 x 27

Included: thermostat transmitter (E901TX), thermostat receiver (E901RX).

E901RF is a programmable, surface-mounted electronic room thermostat, used for control of heating devices (e.g. gas, oil boilers, heat pumps) or cooling devices. It has the function of creating your own schedules. Thanks to the built-in algorithms, it offers a much better temperature control accuracy than traditional mechanical thermostats. E901RF set is paired by factory. Receiver should be connected directly to a controlled device (e.g. gas boiler).

#### Product features:

- has all the features of E901 plus additional
- working range up to 100 m in open space
- wireless communication in 868 Mhz standard
- automatic signal renewal

# MODBUS RTU protocol

## MODBUS RTU

MODBUS RTU is one of the most popular and universal communication protocols in building and industrial automation networks. It allows bidirectional transfer of information between devices operating within the same network. MODBUS RTU protocol is distinguished by simplicity of operation, high efficiency and reliability of the data exchange process.

ENGO Controls uses the RS-485 interface, which provides open serial connectivity based on Master-Slave architecture. The protocol connects field devices, such as controllers, sensors or controllers from different companies, into a facility management system and is widely used in both process automation and manufacturing.

Models of ENGO Controls that communicate via the MODBUS RTU protocol can also connect wirelessly to a Wi-Fi network. Configuration of the devices is done using the ENGO application Smart.



# E MODBUS

## Wi-Fi, MODBUS Thermostat

### E10WMODBUS / E10BMODBUS

▶ AVAILABLE SOON 932332944 / 932332943 white / black



Power supply	230V AC 50Hz
Max current	3 (1) A
Temp. setpoint range	5 – 45°C
Display temp. accuracy	0.1°C
Control algorithm	TPI
	Hysteresis (±0.1°C to ±0.5°C)
Communication	Wi-Fi 2,4 GHz MODBUS RS-485
Control output	NO/COM (voltage-free relay)
Dimensions [mm]	86 x 86 x 39 (14 after mounting in a box with a diameter of 60)

A model with parameters corresponding to the E10 controller, but with the additional function of MODBUS protocol support. A flush-mounted temperature controller that allows economic and ecological control of any type of heating. It is characterized by a clear menu and a multitude of useful functions. It provides remote control of the heating system using ENGO Smart application. Programming of the E10 is very simple and allows to adjust the heating cycle to the users' daily rhythm.

#### Product features:

- communication in the MODBUS RTU standard
- works with ENGO Smart (Compatible with Tuya App)
- possibility to set the minimum and maximum setpoint temperature range
- for Underfloor or Heating Source control
- TPI algorithm ideal for underfloor heating
- diagrams with temperature history (available in the app)
- external temperature sensor input
- push notifications from the app
- voltage-free output



EPC11



EPC11W



EPC12HW

## Pump Controller for CH system

### EPC11

932362891

It is designed to control the water pump in the central heating circuit. The task of the device is to turn on the pump if the temperature exceeds the desired value and turn it on if the boiler cools down (due to shutting down). This prevents unnecessary pump operation and extends its life, which saves electricity.

Power supply	230V AC 50Hz
Max load of the pump output	3(1) A
Temp. measurement range	0 - 99°C
Setpoint temp. range	5 - 80°C
Sensor temp. range	-10 - 120°C
Sensor cable length	1,5m
Dimensions [mm]	155 x 70 x 39

## Pump Controller for CH or DHW system

### EPC11W

932362892

It is designed to control the water pump in the central heating and hot water circulation. It also works as a safety thermostat. It has the ability to turn on and off the pump. The pump starts after exceeding the user-set temperature value „C“, and turns off after exceeding the set shutdown temperature „U“.

Power supply	230V AC 50Hz
Max load of the pump output	3(1) A
Temp. measurement range	0 - 99°C
Adjustable temp. range (ON)	5 - 75°C
Adjustable temp. range (OFF)	10 - 80°C
Sensor temp. range	-10 - 120°C
Sensor cable length	1,5m
Dimensions [mm]	155 x 70 x 39

## Pump Controller for CH and DHW system

### EPC12HW

932362893

The controller turns on when the boiler temperature exceeds the user-set central heating pump activation temperature. The DHW pump works on the basis of a temperature difference. The DHW pump is switched on when the boiler temperature exceeds the tank temperature by the hysteresis set by the user. The hot water pump works until the boiler and tank temperatures equalize or the set tank temperature is reached.

Power supply	230V AC 50Hz
Max load of the CH pump output	3(1) A
Max load of the DHW pump output	3(1) A
Temp. measurement range	0 - 99°C
Setpoint temp. range for CH	5 - 80°C
Setpoint temp. range for DHW	20 - 80°C
Sensor temp. range	-10 - 120°C
CH sensor cable length	1,5m
DHW sensor cable length	3m
Dimensions [mm]	155 x 70 x 39

#### Product features:



plug&play



protection against stagnation of the installation outside the heating season (ANTI-stop function)



manual mode



sound alarm (when water temperature is too high)



frost protection (pump activation at temperature below 5°C)

#### Only applies to EPC12HW:



operation in summer mode (limiting central heating operation outside the heating season)



DHW priority function

## NOTICE

**Producer:**

ENGO CONTROLS S.C.  
Rolna 4  
43-262 Kobielice  
Poland

**Distributor of ENGO Controls brand:**

QL CONTROLS sp. z o.o., sp. k.  
Rolna 4  
43-262 Kobielice  
Poland

**Contact:**

✉ [engo@engocontrols.com](mailto:engo@engocontrols.com)

**Technical support**

✉ [support@engocontrols.com](mailto:support@engocontrols.com)



**engocontrols.com**